

# Thunder Lighting Enclosures



*Now you can use Lekos, profiles, scans and pattern projectors, in fact just about any conventional stage lighting fixture, outside, in any weather – and without breaking the bank... Thunder is easy to hang, stand, pole-mount, wall-mount – whatever, wherever.*

*Thunder is the new family of cost-effective fixed lighting enclosures for high-powered theatrical spotlights. Now you can use the light you trust, in places you don't...*

*Thunder Enclosures are also available with plexiglass covers, for use with moving mirror fixtures. There's a Thunder Scan to suit most of the popular scanners on the market.*



## Thunder 6600

This is your general purpose enclosure for standard ellipsoidals and effects projectors, with plenty of room for scrollers, gobo changers, and ballasts.

## Thunder 6700

Now we're talking 10" Source 4, Robert Juliat Quincy – larger lights, but the same spacious style, and huge tempered optical glass window.

## Thunder 6800

Big, bigger - the 6800 family takes care of 5" Lekos, as well as those 1200W effects projectors you always wanted to use outdoors. And the scan version handles 1200W moving mirror fixtures with ease.

## Thunder 6810/20

Robert Juliat's Mistral is a phenomenal 1200W HMI Profile – and now you can use it anywhere! These enclosures feature a pair of powerful fans to keep Mistral – and its ballast – cool in all weathers.

## And Now...DEC3 Control!

Now you can specify any Thunder enclosure with the benefits of Tempest's patented Digital Enclosure Control System. DEC3™ keeps your equipment warm when it's cold, cool when it's hot, and never, ever allows condensation buildup. DEC3 is fully automatic, and you won't even know it's there.

Unless you need to. DEC3 features RDM remote control and monitoring, so you know what's happening inside every enclosure – a real boon for larger systems.

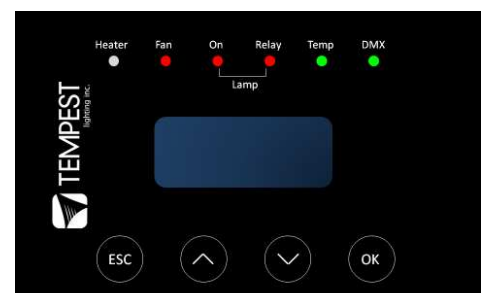

## Enclosure

Fabricated from high-grade aluminum, with stainless steel hardware and weather-sealed tempered optical glass projection window.

## Finish

Exterior grade powder coating: epoxy primer, Cardinal T391-BG290 Bronze Texture. Custom colors to special order.

## Cooling

AC Fan changes the air in the enclosure every 3-5 seconds. Input air filter is easily removed and may be cleaned using water and mild detergent. 6870/6871 models have 2 fans.

## Access

The enclosure cover is removable for installation, focusing and maintenance, providing excellent access.

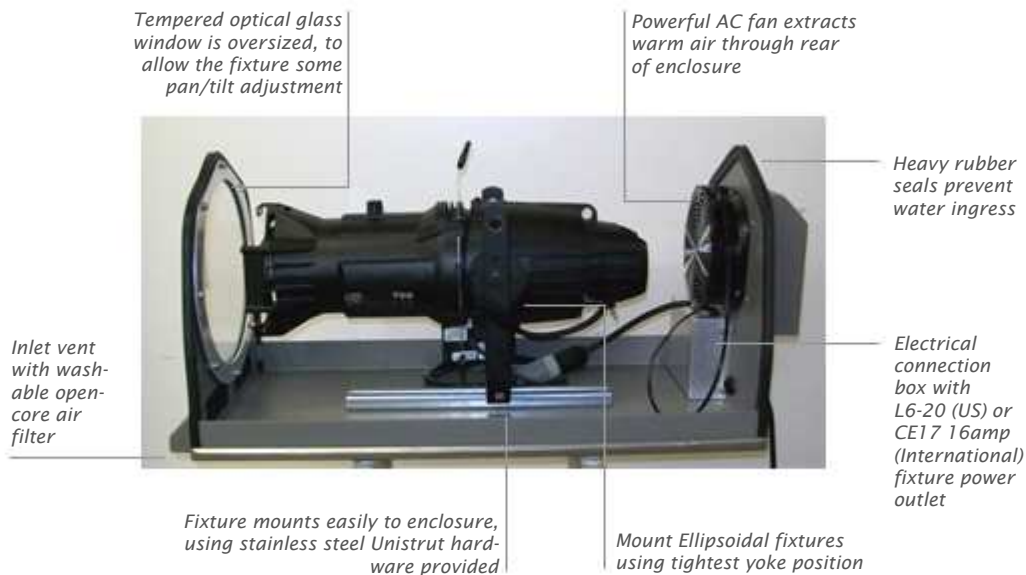

## Security



All Thunder enclosures incorporate stainless steel draw latches, that tightly clamp the cover down onto the enclosure base.

Users may insert rings or padlocks into any of these latches, to guarantee security for the fixtures inside.

Thunder 6600 series enclosures have four draw latches; 6700/6800 series have six.

## Wiring Access

Wiring access conduit entry holes are provided for power, and DMX control. Use these holes to land conduit or flexible conduit (US size 1/2" ID, International 20mm OD), or fit cable glands (not supplied) for flexible cables.

Fixture and fan power may be fed separately if so desired, but it is the user's responsibility to ensure that the fan is powered and running any time the lamp is on. Note that if lamps are controlled by dimmed circuits, then the fan and lamp circuits MUST be separately fed.

1 - DMX/Control Entry

2 - Power Entry

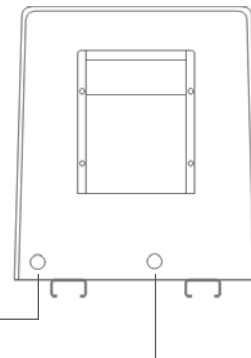

## Digital Enclosure Control?

DEC3™ – that's Digital Enclosure Control, 3rd Generation – takes enclosure control to the next level. DEC3 is an entirely new controller, featuring high-reliability surface-mount electronics, extreme heavy-duty switching components, and a handy waterproof user control panel on the outside of the enclosure. DEC3 offers communication via DMX and RDM, or may be used in its entirely automatic standalone operating mode. DEC3 monitors internal temperature, humidity and lamp current at all times, and uses this information to control its lamp relay, fans and heaters, and report back over RDM if desired.

DEC3 works right out of the box – if you don't want to play with its default settings, you don't need to. DEC3's mission is to maintain temperature and humidity inside the enclosure within the 'Goldilocks' band – never too hot, never too cold, and never, never, allowing deadly condensation to form. Condensation is fatal to electronic equipment, particularly in polluted areas or saline environments, where condensation brings not only rust and short-circuits, but also a steady buildup of mineral and salt deposits. Incidentally, this is very hard to control with air-conditioning type systems, which is why we don't use them.

DEC3's function depends on whether the fixture/projector lamp is on or off:

### Lamp ON

When the projector/fixture is running, the heat from the lamp takes care of humidity, and DEC3 runs the enclosure's fans to change its air every few seconds – ensuring minimal temperature rise above outside ambient.

### Lamp OFF

When the lamp is off, DEC3 goes to work. When conditions are within normal bounds, DEC 3 pulses the heater at a low level to prevent condensation, and gently changes the enclosure air every 30 seconds or so. We call this 'pulse mode', and it is the key to preventing damaging condensation inside your equipment.

If the temperature rises above the top set limit, DEC3 runs the fans to cool it down. In cold conditions, DEC3 will run the heater as required to maintain the bottom set temperature.

And while doing all of this, DEC3 can tell you what's

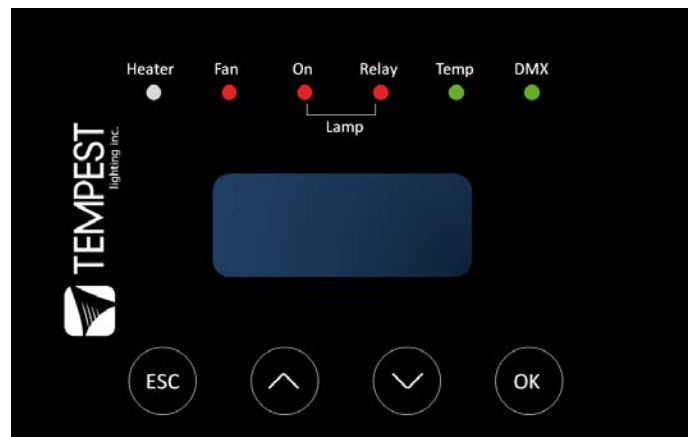

*DEC3's user interface uses capsense™ technology for a watertight control panel that's easy to use and easy to read.*

*LED indicators show the status of all major functions, and the display shows DMX address, temperature, humidity and any error messages you need to know about.*

*Use the simple menus to optimize temperature and humidity settings, set DMX address, view and reset lamp hour counter, and more.*

*And if you need to step back from the Tornado enclosure, all of this is available over RDM, in your control room, or over the internet.*

happening over your RDM network – a real boon in larger installations.

### Operating Modes

**Standalone:** The enclosure operates independently, and automatically, requiring no user intervention. User may set parameters such as temperature and humidity thresholds, and monitor sensor information and DEC status at the DEC3 user interface. Standalone is the default DEC3 setup mode unless specified otherwise.

**DMX:** All of the Standalone features, but the user can override the lamp relay over DMX, to force a hard reset of any moving light that loses its mind!

**RDM:** As above, plus the ability to discover and monitor DEC3 over RDM.

DEC is why, again and again, users around the world have chosen Tempest enclosures to protect their investment in Lighting and projection equipment.

Tempest Lighting and DEC3 – A combination that keeps you looking good, and saves you money.



## Mounting Hardware (optional)

Two parallel 1 5/8" x 13/16" Unistrut. Use standard Unistrut hardware, or order any of the mounting kits below. Tempest uses and recommends only stainless steel mounting hardware.

**4900.MC** Stainless Steel pipe clamp kit, for pipes 1.5" (38mm) to 2" (50mm) OD. Four required per enclosure.

**4925.MC** Stainless Steel pipe clamp kit, for pipes 2" (50mm) to 2.5"/64mm OD. Four required per enclosure.

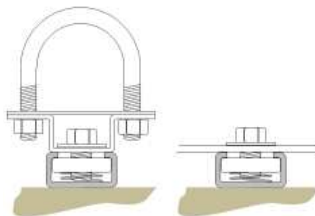

**4900.MB** Stainless Steel Bolt Kit, for attachment to a (user supplied) mounting plate up to 1/4"/6mm thick.

Tempest Lighting, Inc. accepts no responsibility whatsoever for damages arising from deficient mounting design or installation by others.

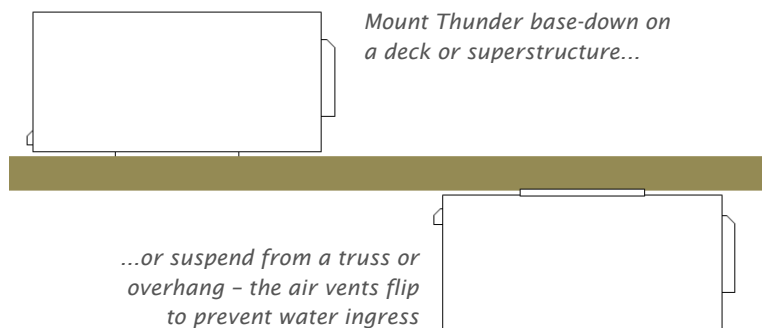

## Dimensions

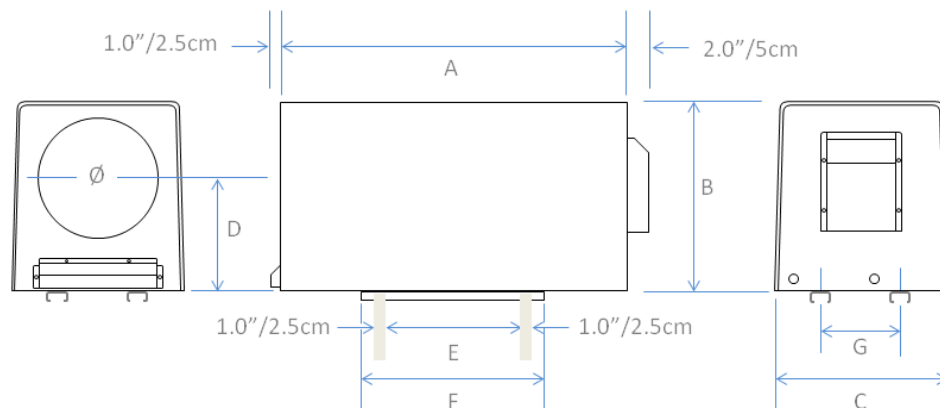

Model	A "/cm	B "/cm	C "/cm	D "/cm	E "/cm <sup>1</sup>	F "/cm	G "/mm	Ø "/cm
66xx	32.5/83	16.5/42	15/38	9/23	11/28	15/38	8/203	10/25
67xx	38.5/98	19/48	16.5/42	11/28	11/28	15/38	12/305	12/30
68xx	45/114	20/51	18/46	11/28	11/28	15/38	12/305	12/30

<sup>1</sup> Shaded areas are obstructed - do not attempt to attach to the Unistrut in these locations.

## Weight

Model	lb/kg
66xx	35/16
67xx	48/22
68xx	60/27

## Approvals

ETL and cETL listed to UL Standard 50, 508

CE: EN55015, EN61000-3-4, EN61000-3-5, EN61000-4-2, EN61000-4-3, EN61000-4-4, EN61000-4-5, EN61000-4-6, EN61000-4-8, EN61000-4-11, EN60598-1

NEMA Type 3R Enclosure (approximately equivalent to IP54)

This product is protected by US Patent Number 6,352,358.

**Ordering Guide:**

Model #	Description	Example Fixture Types <sup>1</sup>	Max Fixture Length <sup>2</sup>	Max Lamp	Volts
6600.IN	Thunder 6600	ETC Source 4 14-50°	26"/66cm	1,200W	230
6600.US	Thunder 6600	Rosco X-Effect,	26"/66cm	1,200W	120
6610.IN	Thunder 6610, DEC3	Strand Leko, Pacific	26"/66cm	1,200W	230
6610.US	Thunder 6610, DEC3		26"/66cm	1,200W	120
6650.IN	Thunder Scan 6650	Most Scans	26"/66cm	1,200W	230
6650.US	Thunder Scan 6650	up to 26"/66cm long	26"/66cm	1,200W	120
6660.IN	Thunder Scan 6660, DEC3		26"/66cm	1,200W	230
6660.US	Thunder Scan 6660, DEC3		26"/66cm	1,200W	120
6700.IN	Thunder 6700	ETC Source 4 10°	32.5"/83cm	1,200W	230
6700.US	Thunder 6700	Zoom, RJ Quincy,	32.5"/83cm	1,200W	120
6710.IN	Thunder 6710, DEC3	Seachanger Nemo	32.5"/83cm	1,200W	230
6710.US	Thunder 6710, DEC3		32.5"/83cm	1,200W	120
6750.IN	Thunder Scan 6750	Most Scans up to	32.5"/83cm	1,200W	230
6750.US	Thunder Scan 6750	32.5"/83cm long	32.5"/83cm	1,200W	120
6760.IN	Thunder Scan 6750, DEC3		32.5"/83cm	1,200W	230
6760.US	Thunder Scan 6760, DEC3		32.5"/83cm	1,200W	120
6800.IN	Thunder 6800	Source 4 5°	39"/99cm	1,200W	230
6800.US	Thunder 6800	Clay Paky VIP 1200,	39"/99cm	1,200W	120
6810.IN	Thunder 6810, DEC3		39"/99cm	1,200W	230
6810.US	Thunder 6810, DEC3		39"/99cm	1,200W	120
6850.IN	Thunder Scan 6850	Most Scans up to	39"/99cm	1,200W	230
6850.US	Thunder Scan 6850	39"/99cm long	39"/99cm	1,200W	120
6860.IN	Thunder Scan 6860, DEC3		39"/99cm	1,200W	230
6860.US	Thunder Scan 6860, DEC3		39"/99cm	1,200W	120
6870.IN	Thunder Mistral 6810	RJ Mistral 923/924 <sup>3</sup>	33"/84cm	1,200W	230
6870.US	Thunder Mistral 6810	RJ Mistral 923/924 <sup>3</sup>	33"/84cm	1,200W	120
6871.IN	Thunder Mistral 6820	RJ Mistral 920 <sup>3</sup>	40.5"/103cm	1,200W	230
6871.US	Thunder Mistral 6820	RJ Mistral 920 <sup>3</sup>	40.5"/103cm	1,200W	120

<sup>1</sup> The fixtures shown are just examples - any luminaire of the general type and within the dimensional and power limits may be used. Thunder 6600-6800 generally accomodate ballasts for discharge versions of the fixtures shown.

<sup>2</sup> Be sure to allow for any accessories that add length when determining which Thunder to use. See dimensional drawings for internal dimensions to calculate accessory clearance. For internal dimensions, subtract 1/2"/13mm from external dimensions shown.

<sup>3</sup> Mistral enclosures accomodate ballast as well as fixture head, and have two fans to remove the additional heat.

**Shipping  
Carton Packed**

Thunder 66xx	36"x18"x18"(h), 45lb	91 x 46 x 46cm, 20kg
Thunder 67xx	48"x24"x24"(h), 58lb	122 x 117 x 117cm, 26kg
Thunder 68xx	48"x24"x24"(h), 70lb	122 x 117 x 117cm, 32kg
Schedule B Export Code: 8536.30.0000		

© Tempest Lighting, Inc., September 2010  
In the interest of continuous product improvement,  
specifications are subject to change without notice



**Production Supplies & Services Worldwide**

tmb-info@tmb.com

**LOS ANGELES**  
Tel: +1 818.899.8818

**LONDON**  
Tel: +44 (0)20.8574.9700

**NEW YORK**  
Tel: +1 201.896.8600

**BEIJING**  
Tel: +86 10.8492.1587

**TORONTO**  
Tel: +1 519.369.9990