

## User Manual and Installation Guide

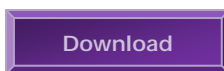

September, 2011

### *Blizzard Series Projector Enclosures*



# DEC3.2

You can download a copy of this manual at  
<http://www.tempestlighting.com/products.html#blizzard>

Tempest Lighting Inc.  
13110 Saticoy Street  
North Hollywood, CA 91605, USA

Tel +1 818 787 8984  
Fax +1 818 982 5582  
[info@tempestlighting.com](mailto:info@tempestlighting.com)

#### Covers:

- all Blizzard models with DEC 3.2 control system manufactured after September 1<sup>st</sup>, 2011
- All Fan-only Blizzard Enclosures
- Includes supplement covering DEC3 control enclosures manufactured prior to September 2011

*In the interest of continuous product improvement, the information in this document is subject to change without notice. Neither Tempest Lighting, Inc. nor its representatives or agents may be held liable for expense or injury arising from it.*

© Tempest Lighting Inc. All Rights Reserved



## Declaration of Conformity

This is to certify that the following products

- 6500.IN Baby Blizzard, force cooled, 230V
- 6505.IN Baby Blizzard, force cooled, 230V
- 6510.IN Baby Blizzard, DEC3 Enclosure Control, 230V
- 6515.IN Baby Blizzard, DEC3 Enclosure Control, 230V
- 6550.IN Blizzard, DEC3 Enclosure Control, 230V
- 6555.IN Blizzard Stretch, DEC3 Enclosure Control, 230V
- 6556.IN Blizzard X-Stretch, DEC3 Enclosure Control, 230V
- 6560.IN Blizzard, Force-cooled, 230V
- 6565.IN Blizzard Stretch, Force-cooled, 230V
- 6566.IN Blizzard X-Stretch, Force-cooled, 230V

are in Compliance with the following standards or specifications according to the EMC Directive 89/336/EEC.

EN55015, EN61000-3-4, EN61000-3-5, EN61000-4-2, EN61000-4-3, EN61000-4-4, pr  
EN61000-4-5, EN61000-4-6, EN61000-4-8, EN61000-4-11

and are in compliance with the following standards or specifications according to the Low Voltage Directive 73/23/EEC.

EN60598-1

This declaration is made by the manufacturer

**Tempest Lighting, Inc.**  
13110 Saticoy Street, Unit C  
North Hollywood, CA 91605, USA

This declaration is based on tests that were conducted on the submitted samples of the above mentioned products. Detailed results can be referred to test reports CET.TE200909 and LVT.Te200909.

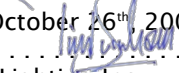
Dated: October 26<sup>th</sup>, 2009  
Signature   
Tempest Lighting Inc





This is to certify that the following products

- 6500.US Baby Blizzard, force cooled, 230V
- 6505.US Baby Blizzard, force cooled, 230V
- 6510.US Baby Blizzard, DEC3 Enclosure Control, 230V
- 6515.US Baby Blizzard, DEC3 Enclosure Control, 230V
- 6550.US Blizzard, DEC3 Enclosure Control, 230V
- 6555.US Blizzard Stretch, DEC3 Enclosure Control, 230V
- 6556.US Blizzard X-Stretch, DEC3 Enclosure Control, 230V
- 6560.US Blizzard, Force-cooled, 230V
- 6565.US Blizzard Stretch, Force-cooled, 230V
- 6566.US Blizzard X-Stretch, Force-cooled, 230V

Have been tested and approved to standards UL 508 (electrical) and UL 50 (environmental), as NEMA 3R enclosures, for use in the United States and Canada.

This declaration is made by the manufacturer

Tempest Lighting, Inc.  
13110 Saticoy Street, Unit C  
North Hollywood, CA 91605, USA

This declaration is based on tests that were conducted on the submitted samples of the above mentioned products.

Listing Report No. 3198609LAX-001a refers.

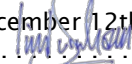
Dated: December 12th, 2010  
Signature  .....  
Tempest Lighting Inc

Tempest Lighting, Inc.,  
13110 Saticoy Street, North Hollywood, CA 91605, USA  
[www.tempestlighting.com](http://www.tempestlighting.com) [info@tempestlighting.com](mailto:info@tempestlighting.com)  
t: +1 818 787 8984  
f: +1 818 982 5582



## *Table of Contents*

Topic	Section
Introduction .....	1
Enclosure Dimensions .....	1.1
Maximum Projector Dimensions and Power .....	1.2
INSTALLATION.....	2
Safety and Warnings .....	2.1
Tools and Equipment.....	2.2
Mounting the Enclosure.....	2.3
Base-up or Base-down Operation?.....	2.4
Mounting the Projector.....	2.5
Wiring .....	3
Wiring for Fan-Only Versions.....	3.2
DEC3.2 Versions – Wiring and Control .....	3.3
Operation – Fan-Only Versions.....	5
Routine Maintenance .....	6
Troubleshooting .....	7
Warranty .....	8
Registration.....	9
DEC3 Control for enclosures manufactured before September 2011 .....	Appendix

## 1 Introduction

### The Blizzard™ Projector Enclosure Family

Thank you for purchasing the Blizzard digital projector enclosure. It will serve you for many years, protecting your 5-15,000 ANSI Lumen projectors from the elements. Although primarily intended for outdoor environments, the design of the Blizzard is such that it can satisfy many other needs. Not only will it protect against hostile outdoor conditions, but also against particulate, smoke, and other indoor conditions that can shorten the life of your digital projector. In addition, you may specify a Blimp option, with soundproofing and a remote fan, for silent operation in theatres and classrooms.

### Products Covered by this Manual

6500	Baby Blizzard, Force-cooled
6505	Baby Blizzard, Force-cooled, Low noise
6510	Baby Blizzard, DEC 3.2
6515	Baby Blizzard, DEC3.2, Low noise
6550	Blizzard, DEC3.2 Enclosure Control
6555	Blizzard Stretch, DEC3.2 Enclosure Control *
6556	Blizzard X-Stretch, DEC3 Enclosure Control *
6560	Blizzard, Force-cooled
6565	Blizzard Stretch, Force-cooled*
6566	Blizzard X-Stretch, Force-cooled*
6590.BK	Blizzard Remote Fan/Soundproofing Kit
6590.BK2	Stretch Blizzard Remote Fan/Soundproofing Kit

*Notes: Part # suffix .US for North American electrical systems*

*Part # suffix .IN for European 230V electrical systems*

*\* North American versions are 208VAV as standard. 120VAC available to order*

### Using This Manual

Please read this manual in its entirety before starting work. All the information contained is important, and should be read carefully before proceeding. Heed all warnings and advisories.

### Icon Key:

① Valuable information

⚡ Electrical Warning

🚫 Safety Information



## 1.1 Dimensions and Weight – Blizzard and Stretch Blizzard

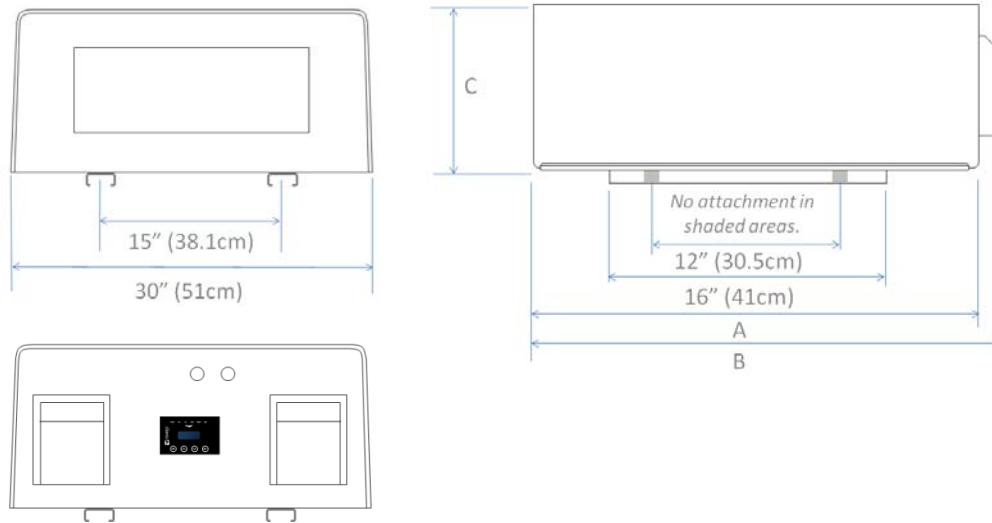

### Maximum Projector Dimensions

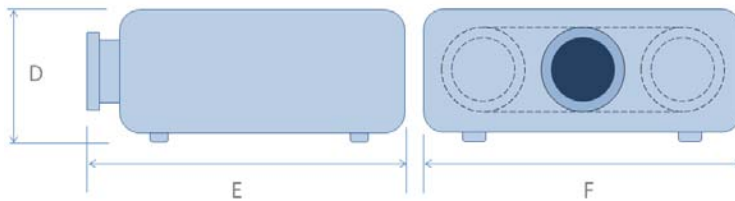







Model #	Description	A	B	C	D	E	F	Weight
6550.US	Blizzard, DEC3 Enclosure Control, 120V	31"/79cm	33"/84cm	14"/36cm	10"/25cm	24"/61cm	26"/66cm	77lb/35kg
6550.IN	Blizzard, DEC3 Enclosure Control, 230V	31"/79cm	33"/84cm	14"/36cm	10"/25cm	24"/61cm	26"/66cm	77lb/35kg
6555.US	Blizzard Stretch, DEC3 Enclosure Control, 120V	41"/104cm	45"/114cm	16"/41cm	12"/30cm	35"/89cm	26"/66cm	97lb/44kg
6555.IN	Blizzard Stretch, DEC3 Enclosure Control, 230V	41"/104cm	45"/114cm	16"/41cm	12"/30cm	35"/89cm	26"/66cm	97lb/44kg
6556.US	Blizzard X-Stretch, DEC3 Enclosure Control, 120V	49"/124cm	51"/130cm	16"/41cm	12"/30cm	42"/107cm	26"/66cm	106lb/48kg
6556.IN	Blizzard X-Stretch, DEC3 Enclosure Control, 230V	49"/124cm	51"/130cm	16"/41cm	12"/30cm	42"/107cm	26"/66cm	106lb/48kg
6560.US	Blizzard, Force-cooled, 120V	31"/79cm	33"/84cm	14"/36cm	10"/25cm	24"/61cm	26"/66cm	67lb/30kg
6560.IN	Blizzard, Force-cooled, 230V	31"/79cm	33"/84cm	14"/36cm	10"/25cm	24"/61cm	26"/66cm	67lb/30kg
6565.US	Blizzard Stretch, Force-cooled, 120V	41"/104cm	45"/114cm	16"/41cm	12"/30cm	35"/89cm	26"/66cm	87lb/40kg
6565.IN	Blizzard Stretch, Force-cooled, 230V	41"/104cm	45"/114cm	16"/41cm	12"/30cm	35"/89cm	26"/66cm	87lb/40kg
6566.US	Blizzard X-Stretch, Force-cooled, 120V	49"/124cm	51"/130cm	16"/41cm	12"/30cm	42"/107cm	26"/66cm	96lb/47kg
6566.IN	Blizzard X-Stretch, Force-cooled, 230V	49"/124cm	51"/130cm	16"/41cm	12"/30cm	42"/107cm	26"/66cm	96lb/47kg

### Maximum Projector Lamp Power – 1,300 Watts

## 2 Installation





### 2.1 Safety and Warnings

These warnings are for your protection. Failure to comply may result in serious injury or death. Tempest Lighting, Inc. assumes no responsibility for damages or injury incurred by misuse or mishandling of product.



-  **Do not** attempt to install or operate the enclosure before fully reading and understanding this manual
-  **Never** allow anyone who has not read this manual to open the enclosure or perform maintenance on the projector within.
-  **Never** leave the enclosure unattended when open.
-  **Always** make sure all bolts and latches are tight and safety locks are in place after performing any form of maintenance on the unit.
-  **Do not** open any electrical boxes until power has been shut off to all supply lines to the enclosure (including the one powering the projector).
-  **Do not** open the enclosure in wet weather.

### 2.2 Tools and Equipment

To install the enclosure, you will need the following items:

-  Crescent wrench
-  Phillips screwdriver
-  Terminal screwdriver
-  Proper wiring installation equipment (for line power and signal wiring)
-  Any equipment listed in the projector manufacturer's projector-specific installation directions

### 2.3 Mounting the Blizzard Enclosure

-  The Blizzard enclosure must be mounted on or under a solid structure rated for the weight of the enclosure, the projector inside it, and at least one person.
-  Snow - if installed outside in cold regions, the bottom of the Blizzard enclosure must be at least 2' (60cm) above maximum height of any snowfall or drifting snow, subject to local conditions. If snow is not a consideration, then enclosure may sit on the ground as long as proper drainage is provided.

❶ LEAVE ADEQUATE CLEARANCE BEHIND ENCLOSURE FOR WIRING AND VENTILATION

❶ *Tempest Lighting recommends the use of stainless steel mounting hardware.*

The Blizzard enclosure is provided with a pair of Unistrut channels on the enclosure base, for mounting to your structure. You may use standard Unistrut accessories, or purchase mounting kits from Tempest Lighting – four kits are required per enclosure.

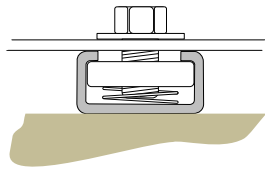

**4900.MB** *Stainless Steel Unistrut channel nut, bolt and washer. Four required per enclosure.*

*Mounting holes  
0.532"/13mm, 4  
places*

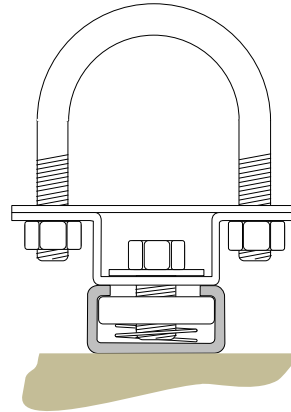

**4900.MC** *Stainless Steel Unistrut channel nut, bolt and pipe clamp, for pipes 1.5" (38mm) to 2" (50mm) OD. Four required per enclosure.*

**4925.MC** *Stainless Steel Unistrut channel nut, bolt and pipe clamp, for pipes 2" (50mm) to 2.5" (64mm) OD. Four required per enclosure.*

**Blizzard and Stretch Blizzard**

Suggested layout for mounting plate, using four 4900.MB kits.

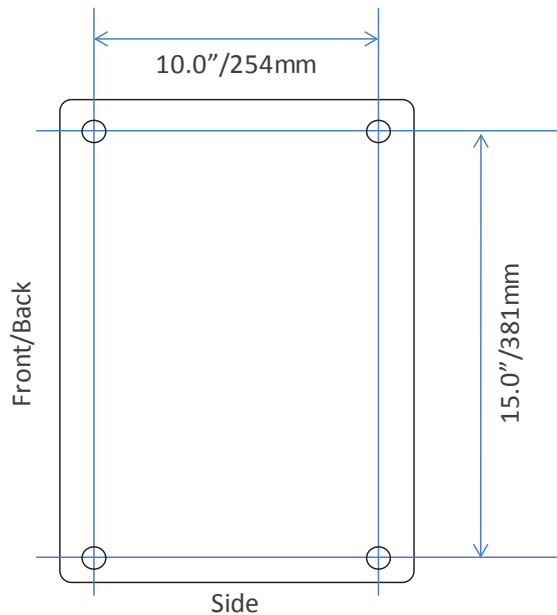

**Baby Blizzard**

Suggested layout for mounting plate, using four 4900.MB kits.

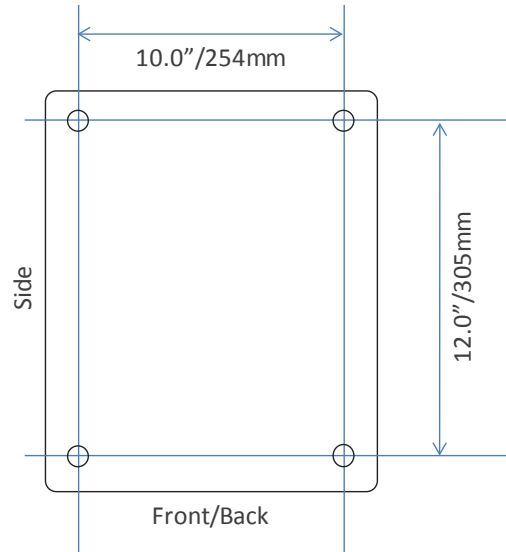

## 2.4 Mounting Base-down and Base-up

All Blizzard enclosures are designed to be mounted base-down, on a solid structure, using Unistrut mounting hardware. They may also be suspended from an overhang, ceiling or truss, using the same hardware. Note that in this event it will be necessary to flip the projector image, since the projector itself will be hanging upside-down. It's important to be sure that the projector to be used supports this feature (usually referred to as Ceiling Mount mode) before commencing installation.

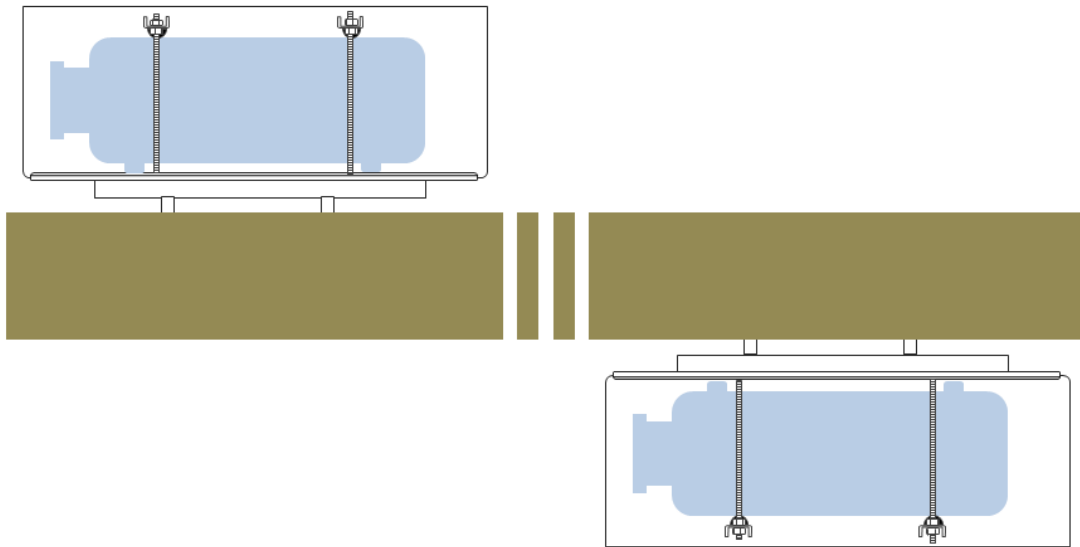

### Air vents for Base-up operation

When the Blizzard is used base-up, remove the front and back air vents, invert, and replace, to prevent rainwater ingress.

*Rear air exhaust vent, inverted for base-up operation. Do the same with the front intake vent.*



### **IMPORTANT SAFETY NOTICE:**

***It is the responsibility of the installer to ensure that all mounting points are secure and conform to local safety regulations. Tempest Lighting Inc. accepts no responsibility for damage or injury arising from inappropriate or unsafe installation.***

## 2.5 Mounting the Projector in the Blizzard Enclosure

**⚠** If the Blizzard enclosure is suspended from a ceiling or overhang, this must be done by two people.

1. Find the best location for the two projector clamps, avoiding contact with access doors, vents and control on the projector top.
2. Make sure that all four Projector clamp threaded rods are screwed into the projector tray, and locked in place with the locknut provided.
3. Remove the projector clamp bars.
4. Place the projector on the projector tray. If hanging the projector upside-down, one person must hold the projector in position, while another person secures the projector clamp bars in place.
5. Replace the projector clamp bars, with the rubber pads pressing firmly onto the projector cover, and tight the nuts above and below each end of each projector clamp.
6. Ensure that the projector is securely held before proceeding further.

*Note: You can still adjust the projector pan and tilt by loosening the projector clamp, adjusting the projector feet, then re-tightening the projector clamp to hold the projector firmly in place.*

*Note: **BABY BLIZZARD** is equipped with a load strap to secure the projector in place.*

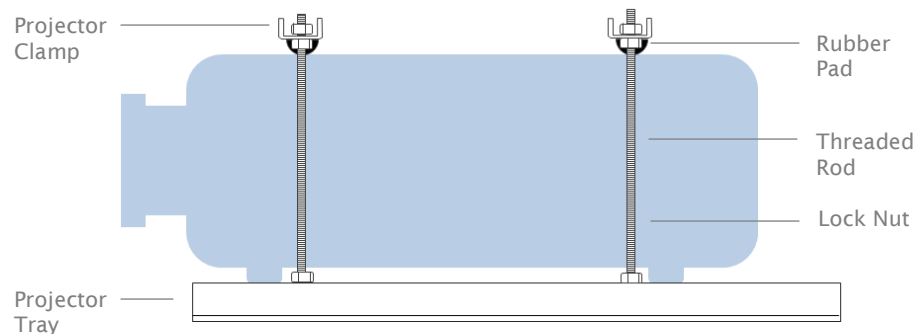

7. Connect the projector power cable to the projector, and plug into the receptacle provided inside the enclosure:

International Versions (.IN part # suffix) are equipped with CE17 16amp 2P+E receptacles

US Versions (.US part # suffix) are equipped with NEMA L6-20 receptacles

8. Connect projector signal cables
9. Tie down any cables away from the exhaust fan
10. Power up the projector, check functions and adjust focus
11. Replace the enclosure cover
12. Make sure that all latches are securely fastened. The latches are adjustable, and should be checked periodically, since the rubber seal may compress slightly over time.
13. For additional security, use a bolt or padlock to lock one or more of the latches, using the security ring provided.

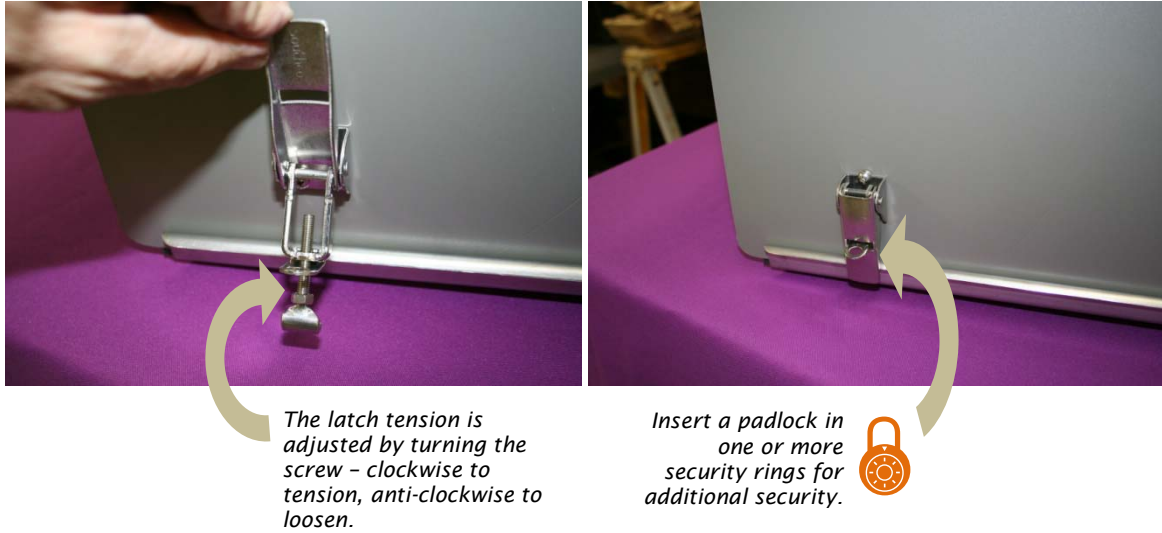

## Installing the Blizzard Blimp Accessory

If you ordered a Blimp kit with your Blizzard, the installation is exactly the same, except that the fan is remote from the enclosure and needs to be installed separately.

The Blimp kit provided with your enclosure comprises additional sound insulation inside the enclosure, plus a remote fan kit.

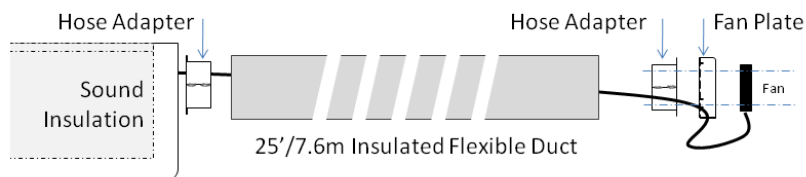

1. Attach a Hose adapter plate to the exhaust air location on the right side of the rear panel, using the four 8-32 screws provided
2. Thread the fan cable through the padded hose provided, using a fish tape
3. Pass the fan cable through the hose adapter, and connect to the FAN terminals inside the enclosure, passing the fan cable through the rubber grommet in the side of the electrical cover.
4. Attach one end of the hose to the hose adapter plate, using one of the clamps provided.
5. Attach the other end to the Fan assembly in the same way, taking care not to crimp the fan cable.
6. Feed the hose through the wall or ceiling to a suitable location and screw in place. This will normally be either in a large ceiling void, or in a remote location with access to outside air.
7. **DO NOT EXTEND** the hose beyond its 25'/7.6m length. It has been tested at this length, and extending it further may reduce cooling efficacy inside the enclosure.

### 3 Wiring

#### 3.1 Electrical Preparation

⚡ **All electrical work must be carried out by a properly licensed electrician. Failure to observe this point will void the factory warranty for the Tempest Enclosure and possibly the projector/projector.**

- 1 Before starting work, switch off power to the branch circuit, carefully following lockout and tag-out procedures. Failure to do so could cause serious injury or death.
- 2 Two or three electrical junction boxes will be required within a short distance of the Blizzard enclosure for:
  - AC Supply wiring (Projector)
  - AC Supply Wiring (Enclosure Fan) – may be combined with projector power feed if desired
  - Projector picture signal wiring

- 3 Your Blizzard enclosure is supplied fitted with two cable entry points, suitable for flexible conduit fittings. US size ½”, international 20mm.

Note the locations of the cable entry fittings on the rear panel

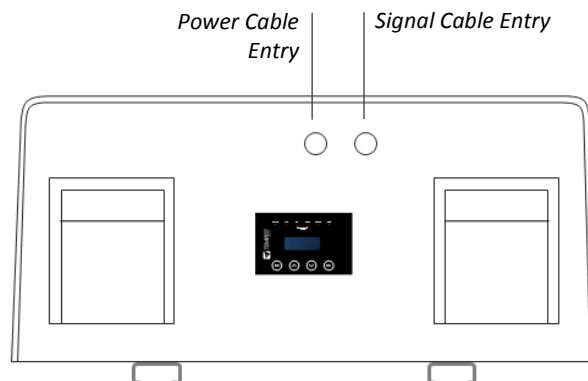

- 3 All junction boxes must be installed in accordance with local electrical codes and should be located near the permanent installation of the enclosure. Each junction box requires a length of flexible conduit, long enough to reach from junction box to the enclosure conduit fittings. Leave slack for positioning of enclosure, and enough space behind the enclosure for ventilation.
- 4 The AC supply must be protected by a fuse or circuit breaker of a rating suitable for the projector. For the DEC3 versions, add max 550W load for the enclosure fan and heater.
- 5 The user may connect the fan and the projector to the same switched supply, or run them separately, according to need. If run separately, it is the user’s responsibility to ensure that the fan is always running when the projector lamp is on.

### 3.1 Fan- Only Versions:

Remove the electrical cover inside the enclosure. You will see the fan wires already terminated to the connector block on the rear panel.

Pass the AC feeder wires through the rear panel and terminate to the connector block, using one of the wiring diagrams below.

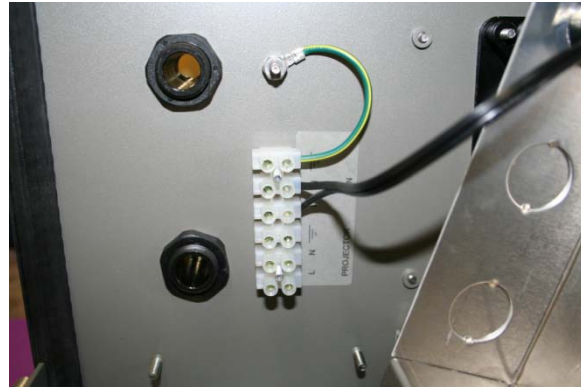

Feed the projector power cable through the grommated hole in the electrical cover, and terminate as shown in the wiring diagrams below.

Replace the electrical cover, taking care not to pinch any of the power wires.

Use the second cable entry to run projector signal and control cables to the projector, as specified by the projector manufacturer.

#### Wiring Diagrams

120V Dual Feed

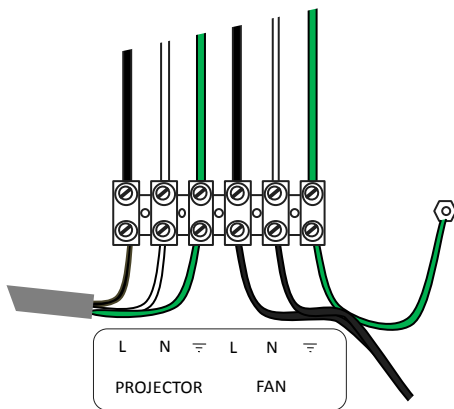

120V Single Feed

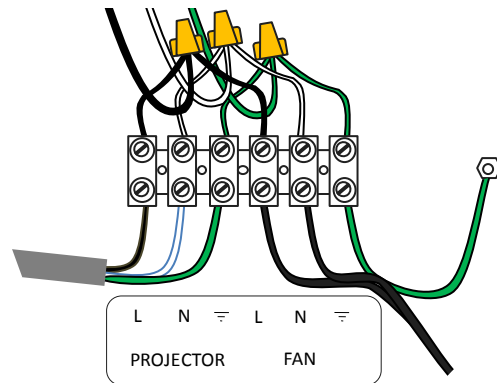

230V Dual Feed

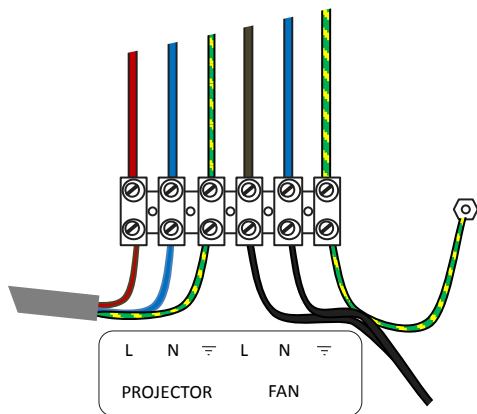

230V Single Feed

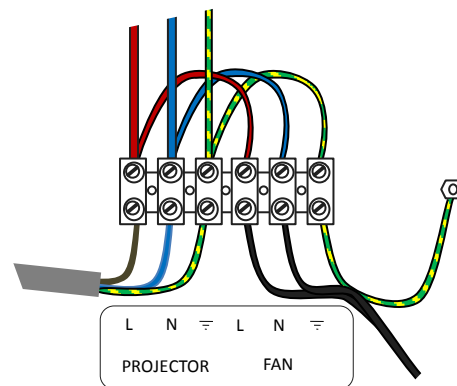

## 3.2 Wiring for DEC Versions

These instructions are for the installation of Projector Enclosures featuring Tempest's DEC3 Digital Enclosure Control System (DEC3™). Your enclosure has DEC3 control if you see a control panel on the rear surface like this:

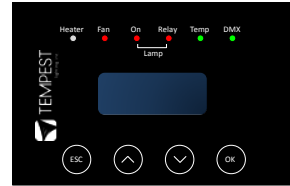

### **IMPORTANT:**

**Blizzard enclosures manufactured from September 2011 ship with DEC3.2 control, described in the following section.**

**For Blizzard enclosures manufactured before September 2011 with DEC3 control, see the appendix at the end of this manual.**

## DEC 3.2 Control – Introduction

Tempest Lighting and Projector Enclosures have been in daily use around the world for almost a decade. Tempest enclosures protect expensive and delicate equipment in all climates, maintaining a comfortable operating temperature, and preventing condensation – the real outdoor enemy.

DEC3.2™ – that’s *Digital Enclosure Control, third Generation, revision 2* – is the brain of your Tempest enclosure. It will maintain the internal environment in a comfortable temperature and humidity range, and prevent condensation – the real equipment killer. DEC3.2 monitors internal temperature, humidity and lamp current at all times, and uses this information to control its lamp relay, fan(s) and heater(s). It can report back over the DMX cable, using the RDM protocol (Remote Device Management) if desired.

Unless otherwise specified, this version of the user guide refers to DEC3.2 units fitted with software version 0.1.xxx or later.

### So, what does DEC3.2 actually DO?

The DEC3.2 Engine is the brains of the operation – here’s a layout:

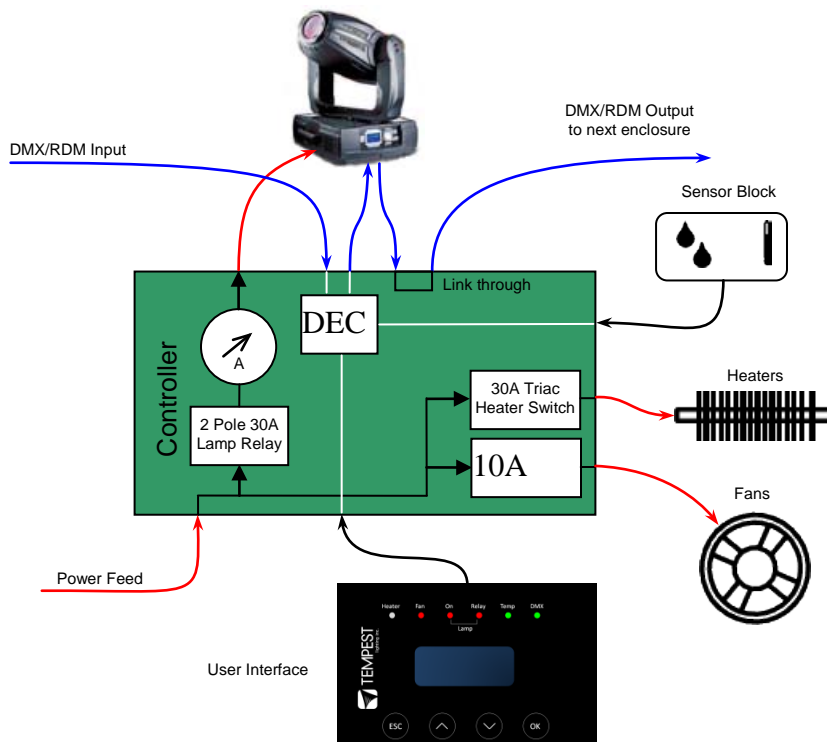

*This schematic shows the relationship between DEC3.2's functional elements.*

*The power supply is universal 100-240V, but fans and heaters are either 120V or 230VAC, and must be so specified.*

*High-quality, high power Electro-mechanical relays provide two pole power isolation for the enclosed the fixture/projector in the event of an over-temperature condition.*

*Fans and heaters are switched using generously overrated Triac devices for maximum reliability.*

*4 DMX connections are provided to facilitate field termination of DMX inputs and outputs via the enclosed fixture and the controller.*

DEC3.2's mission is to maintain temperature and humidity inside the enclosure, within determined bounds, and to prevent condensation – particularly overnight dew formation – inside the equipment housed. Condensation is fatal to electronic equipment, particularly in polluted areas or saline environments, where it brings not only rust and short-circuits, but also a steady buildup of mineral and/or salt deposits. Incidentally, condensation is very hard to control with air-conditioning type systems, which is why we don't use them.

Broadly speaking, DEC3.2's function depends on whether the fixture/projector lamp is on or off:

#### **Lamp ON**

When the projector/fixture is running, the heat from the lamp takes care of humidity, and DEC3.2 runs the enclosure's fan(s) to change its air every couple of seconds – ensuring high-velocity forced-air cooling while the lamp is on.

#### **Lamp OFF**

When the lamp is off, DEC3.2 senses temperature and humidity and controls its fan(s) and heater(s) accordingly. When conditions are within normal bounds (between top and bottom temperature settings and below the humidity threshold (see below), DEC3.2 pulses the heater at a low level to dry the air and eliminate condensation, and runs the fans to change the enclosure air every 30 seconds or so. We call this 'pulse mode', and it is the key to preventing damaging condensation inside your equipment.

If the temperature rises above the top set limit (see below), DEC3.2 runs the fans to cool it down. In cold conditions, DEC3.2 will run the heater as required to maintain the bottom set temperature.

Thus, DEC3.2 maintains a comfortable operating temperature inside the enclosure, and prevents damage from condensation. Users all over the world have found that Tempest enclosures provide an optimal environment for expensive and delicate equipment, in every climate type.

And while doing all of this, DEC3.2 can tell you what's happening over your RDM network – a real boon in larger installations. You may also use RDM to configure your Tempest installation remotely, using an appropriate RDM front end.

## ***Default Operation***

In most lighting and in almost all projector enclosure applications, DEC3.2 will work just fine with its factory default settings. *You do not need to do anything* other than connect power and switch on. We call this *Basic mode*, and it will apply to most installations. If your needs are more complex, read on.

If not, you can skip to the Power Connections section below.

## ***Operating Modes***

DEC3.2 may be run in one of three basic operating configurations with a fourth configuration for test and service use by trained personnel only. In the RDM context, these configurations are the

device's DMX PERSONALITY. The DEC3.2 mode or personality may be configured from the Front Panel or by using an RDM control. In all configurations, the fixture inside the Tempest enclosure may also be an RDM enabled device.

### **Basic Mode**

This is the way your DEC3.2 controller will normally ship from the factory. It will be set up for standalone operation, with settings that will be appropriate for most installations.

In most cases, Basic Mode will work fine for you. You only need to change it if you will be using DMX or RDM (and if these terms are not familiar to you, you probably won't) or if you have to deal with extreme climate conditions.

You may set temperature and other parameters while using Basic Mode.

### **Monitor Mode**

The enclosure operates independently, and automatically, requiring no user intervention. Users may set parameters such as temperature and humidity thresholds, and monitor sensor information and DEC status at the DEC3.2 using the display, or remotely, using RDM over a DMX512 network. In this mode, the DEC3.2 does not need to "see" any DMX to operate.

### **Control Mode**

This mode has all of the Monitor Mode features plus control of the Lamp Relay using a single DMX slot at the address configured as the DEC3.2 DMX start address.

A DMX slot value (level) > 75% will cause the fixture to be powered and less than 25% will disconnect the power from the fixture. On DMX fail, the Lamp Relay will default to power the fixture, unless it detects a thermal condition that would cause it to isolate power from the fixture/projector.

DMX control of the Lamp Relay has the useful attribute of enabling the user to remotely force a hard reset of the fixture by controlling power to it. This mode is recommended for show-control applications, where it is desirable to have power control of the internal fixture and accidental loss of the DMX data is very unlikely to occur.

To force a hard fixture reset, take the enclosure's DMX channel to zero (or any level below 25%), allow time for the fixture's power supplies to fully discharge, then restore the enclosure's DMX channel to full (or a level above 75%).

### **Service Mode**

This mode is intended for test and service use only, giving the user direct control of the Lamp Relay, fan and heater controls over three DMX slots. Users may NOT override any of the controls in an unsafe direction – for example, if the DEC3.2 has determined the enclosure is over-temperature and has switched off the power to the fixture, the Lamp Relay may not be controlled by DMX. In this sense, DMX

'piles on' to DEC3.2 operation, within defined safety limits. However, until such time as the temperature reaches the TOP limit, the heater may be enabled and the fan disabled, which is why the mode should only be used for Test and Service use by a trained technician.

## DEC3.2 Control Parameters

DEC3.2 will run out of the box with its default parameter settings, which equate to the (fixed) settings of its predecessor DEC's 1 and 2.

### Temperature:

**Top Set**            *Range 35-45°C, Default = 40°C*  
 Most manufacturers recommend a max temperature for their equipment of 40°C, though this does vary. When DEC3.2 senses a temperature higher than Top Set, it indicates an overtemp condition as a warning. NOTE: in moving light enclosures the thermal sensor is necessarily placed in the exhaust air path, which will be higher (sometimes a lot higher) than the actual fixture ambient. This needs to be kept in mind when adjusting temperature settings.

**Cutoff Temp**      *Range 0-15°C, Default = 15°C*  
 This is a setting *above* the Top Set temperature that determines the temperature at which the lamp relay is opened cutting off power from the fixture/projector. User may reduce it as desired, but should establish before doing so the actual operating temperatures experienced in hot weather before doing so, to avoid nuisance tripping.

**Bottom Set**        *Range 0-10°C, Default = 10°C*  
 The temperature maintained by the heater in cold conditions. Most equipment manufacturers recommend a minimum operating temperature of 0°C, and users may set it lower than the default if desired.

**Humidity**            *Range 50-90%, Default 80%*  
 The threshold at which incoming air is more aggressively heated to remove moisture.

**DMX Address**      *Range 001-510, Default 001*  
 Sets the DMX address for the lamp relay control. In the DMX/RDM service mode, the subsequent two DMX slots control fan and heater respectively.

**Fan Overrun**        *Range 1-15 minutes, Default 5 minutes*  
 This is the time that the enclosure fan(s) will run after the fixture/projector lamp is turned off. As a general rule, the more powerful the lamp, the longer the overrun should be, to prevent overheating while the lamp cools down.

**Temp C/F**      Default Celsius  
DEC3.2 displays temperatures in Celsius or Fahrenheit.

**Lamp Hours**      *Default 0000*  
DEC3.2 counts the hours your projector/fixture lamp is on, and can report it both on the user interface display and over RDM. Remember to reset to 0 when changing lamps. This is provided to allow lamp hours monitoring on devices such as Video Projectors that have no native RDM or DMX support.

## 4 Setup and Connections

### DMX Connections

Most projector applications will NOT require DMX, in which case you may skip this section. DMX refers to USITT DMX512, a commonly used control protocol in the entertainment industry, running over RS485. Consult USITT DMX installation guidelines when laying out a system, or employ a qualified DMX system integrator.

Note that DMX is optional - in many applications it is not required, and need not be connected. A DMX network will be required if:

- a) The projector inside the enclosure requires a DMX control signal
- b) You wish to monitor the enclosure using RDM
- c) You wish to control the projector power over DMX

### DMX Terminations

Pinout: (1) Ground, (2) Data -, (3) Data +.

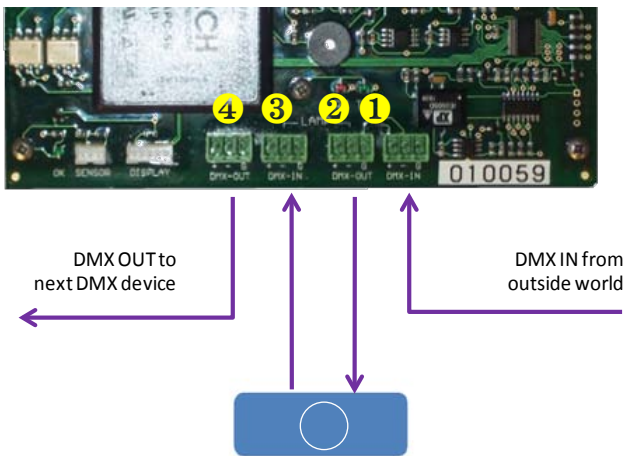

The picture shows the 4 DMX connections on the controller. The incoming DMX feed should always be wired to DMX-IN (1). If the enclosed projector shares the DMX signal, the projector's DMX IN should be wired from connection (2) and its DMX OUT wired to connection (3). Connection (4) will then be the DMX OUT for the enclosure. *If the enclosed projector does not use the DMX connection, then DMX connection (2) on the controller becomes the DMX OUT for the enclosure.*

DMX cable runs must be terminated at the far end of the cable run with a termination resistor as detailed in the DMX512 standard.

The individual projectors installed inside the Tempest enclosures must NOT be terminated. It is recommended that any line termination is done using the 3-pin terminal connector fitted to the DEC3.2 control circuit board.

## RDM Connections

RDM refers to ANSI E1.20, a control protocol in the entertainment industry gaining popularity and essentially an “extension” of DMX512. The use of RDM is optional, and uses the same RS485 cable connection as DMX512, so no additional wiring is required.

It is the responsibility of the user to ensure that any DMX splitters or other routing devices used are rated for RDM as well as DMX use.

## Power Connections

**IMPORTANT** Tempest enclosures are supplied for either 120VAC 50/60Hz, or 208-240VAC, 50/60Hz operation. Tempest Lighting is not liable for damage or failure to operate correctly due to connection to an inappropriate electrical supply.

**ALL ELECTRICAL CONNECTIONS MUST BE UNDERTAKEN BY A QUALIFIED ELECTRICIAN, IN COMPLIANCE WITH LOCAL NORMS AND STANDARDS.**

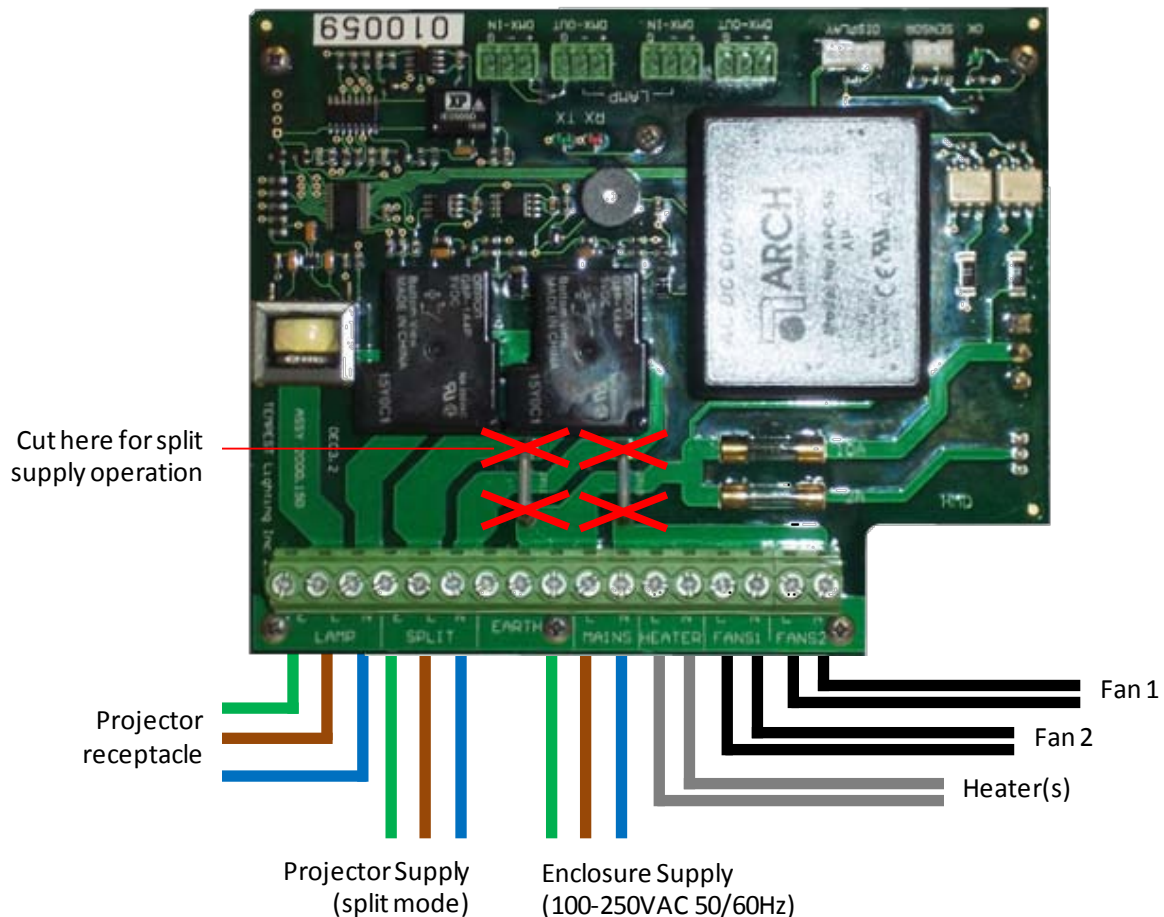

*Note: wire colors may differ depending on applicable electrical standards. European wire colors are shown here.*

**MAKE SURE THAT TERMINAL SCREWS ARE FULLY BACKED OUT BEFORE INSERTING WIRES**

## Split or Common Supply Wiring

**IMPORTANT: Tempest enclosures with any generation of DEC control MUST be powered 24/7, in order to protect equipment from condensation and temperature extremes.**

The AC power feed must be adequate and appropriately fused/protected for the greater of the projector load (see manufacturer's instructions) and the Tempest enclosure (see enclosure manual). *Since the enclosure heater(s) never operate when the projector lamp is on, it is NOT necessary to rate the power service for the SUM of the enclosure and the projector.*

### Common Feed operation (factory default)

Tempest Enclosures are normally supplied wired for common electrical supply for the enclosure (DEC3.2) and the projector/light fixture to be enclosed.

Connect incoming power to the terminals labeled MAINS:

(E) Earth/Ground (L) Live (N) Neutral

### Split Feed Operation

Split Feed allows you to run the projector/light fixture independently of the enclosure. **The enclosure must be powered 24/7.**

DEC3.2 normally ships from the factory with circuit card power links in place for a common electrical supply to feed the enclosure and the projector/fixture inside it.

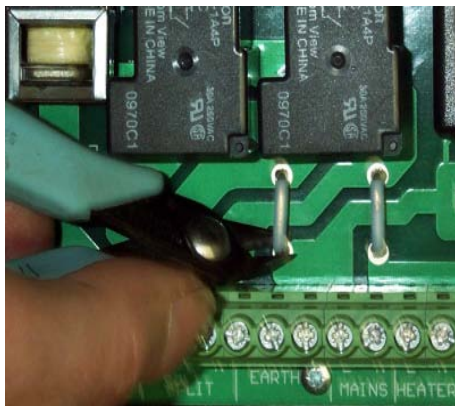

To feed the enclosure and projector separately, you will need to remove the bridging links on the controller circuit board as shown in the illustration, before connecting to mains power.

Use a pair of small side cutters to cut the bridging links from the circuit board, taking care to not damage any tracks on the card.

When splitting the feeders, we strongly recommend feeding both supplies from the same phase and at the same supply voltage.

Feeds must be adequately dimensioned and fused for the loads used.

Connect incoming enclosure power to the terminals labeled MAINS. This supply MUST be maintained 24/7.

(E) Earth/Ground (L) Live (N) Neutral

Connect incoming projector power to the terminals labeled SPLIT:

(E) Earth/Ground (L) Live (N) Neutral

## *Important – RDM and RDM Integration*

DEC3.2's RDM implementation allows system integrators to set up remote control and status monitoring of all attributes and sensors, including:

- Relative Humidity
- Air Temperature
- PCB Temperature
- Lamp Current
- Elapsed Lamp Hours
- Lamp Relay Status
- Fan Relay Status
- Heater Relay Status
- DMX Status
- DMX Start Address
- DMX Personality (RDM Mode)
- Device Type
- Device Label
- Software Version



*RDM is an effective and powerful tool for commissioning and monitoring an installation, particularly in large systems. For further guidance, we recommend you consult a qualified RDM system integrator. If you don't have one in your neighborhood, go to [www.tempestlighting.com](http://www.tempestlighting.com), and click on the RDM and RDM Integration bug on the FAQ page for some useful contacts. Tempest Lighting warrants DEC3.2 to be compliant with the RDM standard, but is not an RDM systems integrator, and can offer only basic guidance on RDM utilization.*

## Control Interface

The control interface features a 2-line display, LED indicators, and 4 sealed control buttons.

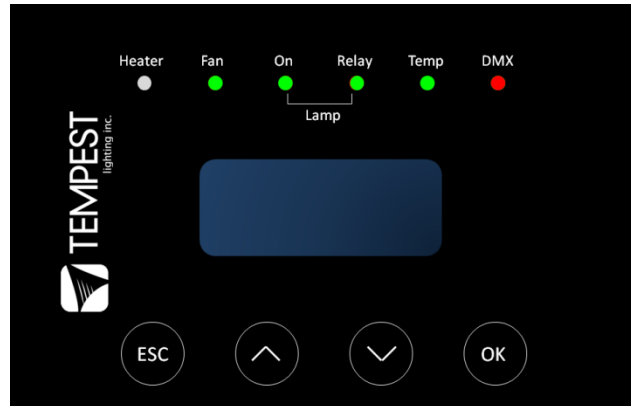

### LED Indicators

#### Heater

SHORT PULSES (Green) – Indicates lamp is off, and the heater is pulsing to prevent condensation inside the enclosure and projector/light fixture. This is normal operation when the lamp is off and the temperature range is above the bottom set limit. Timing intervals may vary – this is normal.

ON (Green) – Indicates heater is on, due to temperature being below bottom temperature setting when lamp is off.

OFF – indicates lamp is on and maintaining temperature above bottom limit.

#### Fan

SHORT PULSE (Green) – The fan is moving a little air through the enclosure, as part of the condensation prevention strategy. The fan comes on for a few seconds approximately every 30 seconds.

ON (Green) – Fan is running, due to lamp being on or internal temperature exceeding top limit.

#### Lamp On

ON (Green) Indicates current sensed on the lamp circuit greater than 0.5 amp (this allows some current to be drawn for such things as fans and control electronics without the Lamp On indicator lighting. When the Lamp On indicator is on, the lamp counter is counting lamp life.

#### Lamp Relay

ON (Green) – Indicates lamp relay closed and power is available to the internal fixture.

OFF Indicates lamp relay open and power is removed from the internal fixture.

#### Temp

ON (Green) – The temperature is between Bottom and Top temperature settings.

ON (Red) – The temperature is either:

- a) Below Bottom Setting
- b) Above Top setting but below the Cutoff level.

FLASHING (Red) – Temperature is above Cutoff level or below Bottom level.

DMX (Not used in BASIC Mode)

OFF – No DMX received (Basic Mode)

ON (RED) – DMX Fail

ON (GREEN) – Good DMX or RDM data packet received. Note that in Monitor Mode the DMX indicator will only be green when RDM packets are being received. In this case a RED LED is not indicating DMX failure, just that no data is being received from the RDM monitor.

## Control Interface Operation

The Control Interface is normally LOCKED.

To UNLOCK, hold ESC and OK together for 5 seconds.

You are now in the CONTROL MENU

Use the arrow keys to scroll up and down the menu.

Press OK, to enter a menu item, then the arrow keys to set the item parameter, or to scroll to the next menu level.

Use ESC to back up a level, and OK to confirm settings.

To LOCK, hold ESC for 5 seconds. Menu will time out after ten minutes.

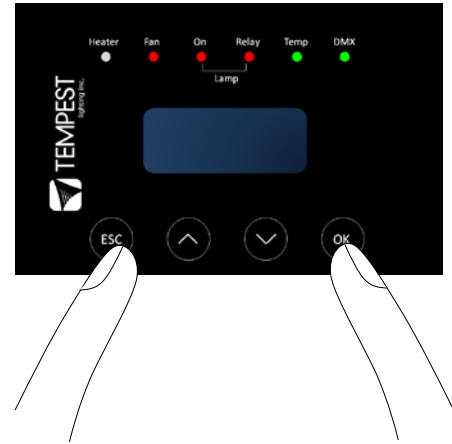

## CONTROL MENU

### SET DMX ADDRESS (in Monitor, DMX or Service modes)

Select a DMX starting address in the range 001 to 510

1 – Lamp Relay

In Service Mode an addition two slots are available

2 – Fan Relay

3 – Heater Relay

*Note that the DMX control is designed using a SAFETY pile-on Logic. So the DMX input can only override automatic settings in a safe manner. For example, if the enclosure has switched off the lamp relay due to an over-temperature condition, the DMX input cannot switch it on, if the fans are running because of Overtemp, the DMX input cannot turn them off, and so on.*

### SET DMX MODE

From the Front Panel, this menu item allows the user to check (and if necessary change) the RDM mode.

BASIC Standalone operation, no DMX/RDM (factory default)

MONITOR Standalone, plus support for RDM remote configuration and monitoring

CONTROL Monitor, plus use of a single DMX address to control Lamp relay

SERVICE Monitor, plus use of three DMX slots to control Lamp, heater and fan

**Important: Please ensure that the DEC3.2 is NOT left in Service Mode.**

## STATUS DISPLAY

View current status information, using the arrow keys to scroll through:

- a) Humidity – relative humidity in %
- b) Firmware version
- c) Lamp Hours elapsed
- d) Current being drawn by projector/light fixture, in amps
- e) PCB temperature
- f) Air temperature, in degrees C or F (note that sensor is placed in the exhaust airflow in Tornado enclosures and may be higher than the temperature being ‘seen’ by the fixture body or electronics)

## RESET LAMP HOURS

The lamp hour counter needs to be reset each time you change the lamp in the fixture/projector. Make this a part of your maintenance instructions.

## HUMIDITY SET

The humidity level above which the heater kicks in to remove humidity from incoming air (default 80%, permissible range 50-90%).

## SET FAN OVERRUN

The fan will continue to run for a time after the internal fixture has gone to standby. This facility allows the heat built up in the fixture to dissipate before the DEC3.2 resumes normal maintenance of the enclosure.

(default 5 minutes, permissible range 0-15 minutes)

## SET TEMP RANGES

Set three temperature trigger points for Bottom, Top and Cutoff temperatures.

### TEMP BOTTOM

The desired lower temperature limit for normal operation

(default 10°C, permissible range 0-10°C).

### TEMP TOP

The desired upper temperature limit for normal operation

(default 40°C, permissible range 35-45°C).

When the DEC3.2 sees air above this temperature, but below the additional Cutoff temperature (see below), it indicates a temperature error. This is not dangerous.

### TEMP CUTOFF

The desired upper temperature ABOVE the TOP TEMP setting, at which the lamp relay is forced to open, isolating the fixture/projector power.

(default 15°C, permissible range 0-15°C).

To avoid nuisance tripping, set this variable to the maximum, and monitor actual temperatures in your normal operating conditions. If your actual temperatures are

running lower, then you may reduce the cutoff temperature margin. In hot climates, it may be advisable to set both TOP TEMP and CUTOFF TEMP as high as possible.

#### SET TEMP C OR F

Choose to display temperature values in Celsius or Fahrenheit (default Celsius)

## RDM Monitoring and Configuration

All the features accessible over the DEC3.2 control panel are also available over RDM. Just how this information is displayed will depend on the RDM interface used. The following screen shots were taken running the GetSet program in Windows 7, and connecting to a DEC3.2 controller using a RDM TRI MK1 interface, both from JESE Ltd (jese.co.uk).

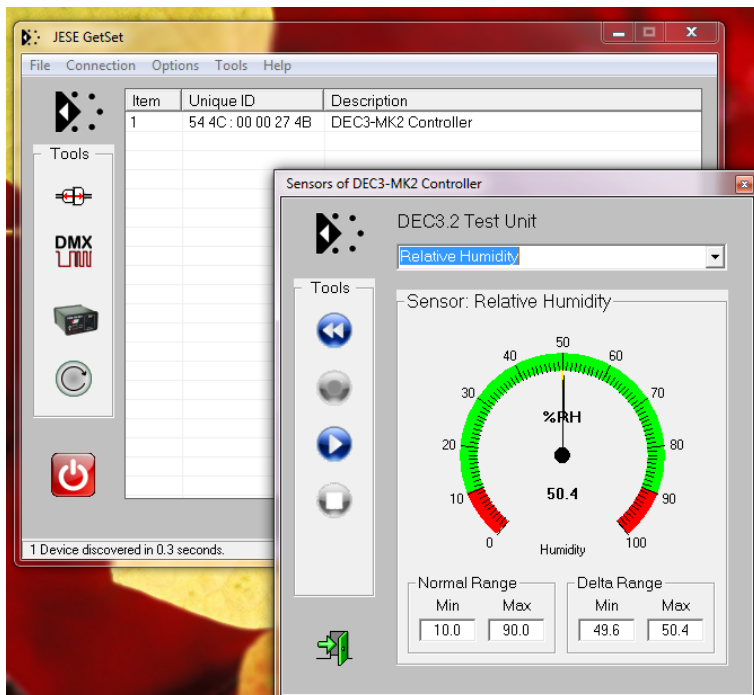
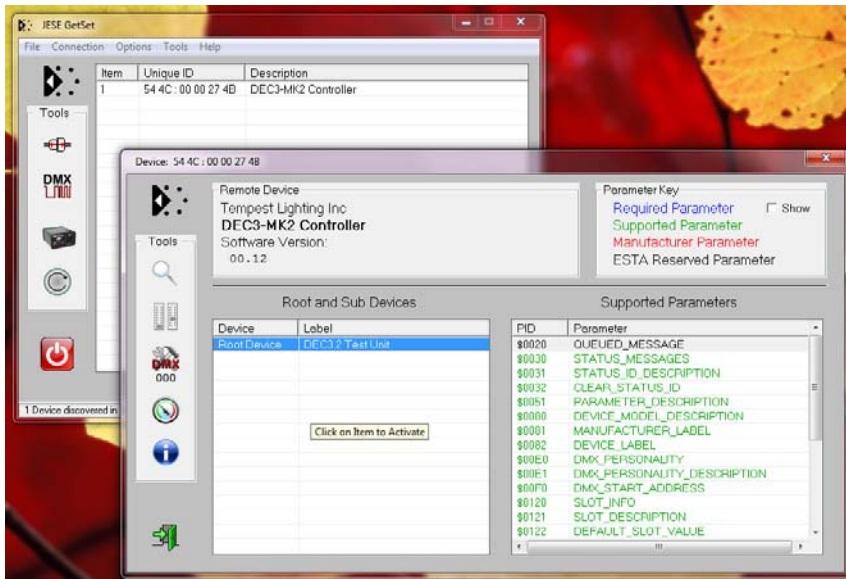

This view shows a single DEC3.2 test unit that has been correctly discovered and labeled by the GetSet software suite, and a log of RDM messages.

This RDM interface provides a graphic view of the various sensor functions supported by DEC3.2 (humidity, air temperature, pcb temperature).

There is a great deal of variability in the way RDM interfaces handle generic and manufacturer-specific information. We recommend

asking your RDM interface vendor whether he has tested his interface with Tempest enclosures and all other RDM devices you plan to use on the same network.

## Firmware Upgrade over RDM

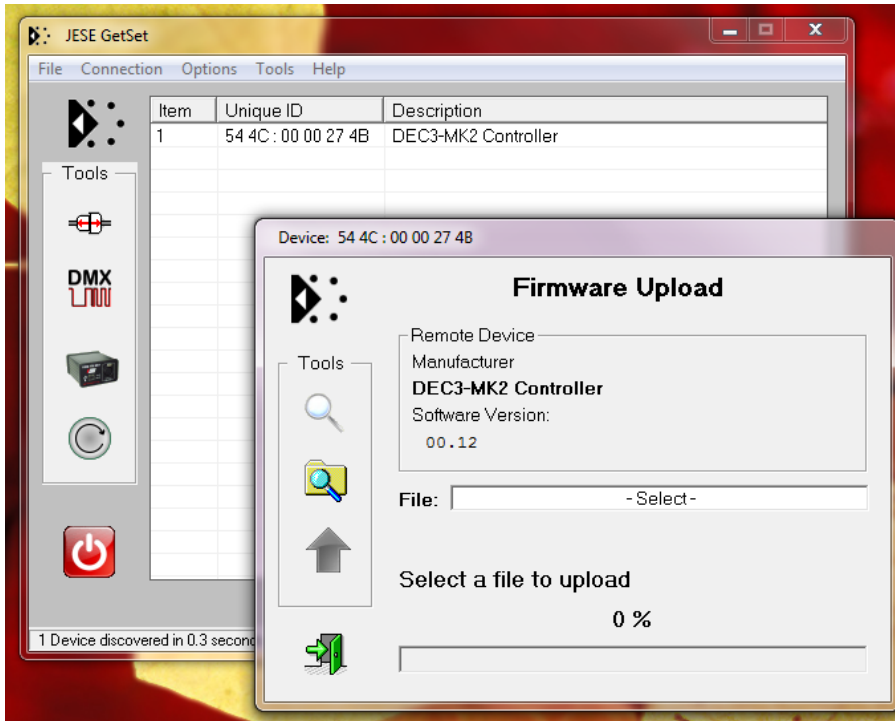

DEC3.2 firmware is now field-upgradeable, using RDM. A field upgrade requires a JESE RDM TRI MK1 interface to be connected to the DMX network on which the DEC3.2 is located, and the use of JESE GetSet software.

## ***5 Operation – Fan- Only Versions***

While there are no specific operational actions required for normal use, the following points should be kept in mind.

- ① **IF the fan and projector have been powered separately, it is the responsibility of the user to ensure that the fan is running at all times when the projector lamp is on.**
- ① Unless the enclosure or projector is undergoing routine maintenance, the enclosure should be closed and securely latched at all times.
- ① Only authorized personnel should open the enclosure (see maintenance warnings in the next chapter).
- ① **Do not routinely operate projector in full sun in hot weather. The enclosure has not been designed to protect the projector in this condition.**





## 6 Routine Maintenance

It is very important to perform routine maintenance on both the enclosure and the projector inside it. Failure to do so may reduce lifetime for both the enclosure and the projector.

### Note

*Maintenance schedules depend on location and environment. The intervals given here are general minimum guidelines. It is up to the user to judge whether maintenance should be carried out more frequently. We recommend doing these tasks no less often than mentioned here.*

### Safety

-  As the enclosure is a powered unit with moving parts, it is necessary to keep safety in mind while performing routine maintenance. Although maintenance can be performed while the enclosure is powered, it is safer to carry it out with the power disconnected with proper lockout and tag out procedures followed.
-  Be aware that once the enclosure has had power applied to it, the fan will start to turn. Make sure that your hands are clear of the fan before applying power to the enclosure.
-  Only authorized personnel should perform maintenance on the enclosure or projector
-  Do not service the unit in the rain or other adverse weather conditions (snow, sleet, high winds, etc.).

### Inspection Checklist: - Every Three (3) Months

- Glass should be clean and free of cracks
- Enclosure should be free of debris both inside and out
- Bolts and tie-down straps should be tight
- Door seals should be in good condition. Check seals inside and out for gaps.
- Fan should be functioning and not making excessive noise
- Intake filter should be clean

### Air Filter - Every Three (3) Months

The air filter from the intake vent on front of enclosure (back on 6550/6560) should be removed and cleaned on a regular basis. To remove filter, pull it directly out of the intake vent. The filter can be cleaned by running water from a hose and do not require any special solution.

To reinstall, push filter back into Velcro on the bottom of the intake vent. Filter should be flush with bottom of vent.



**Case - As Needed**

The outside of the case should be cleaned as needed. The case should be cleaned with a wet cloth and mild detergent (if necessary). Do not use a direct spray from a hose to clean the case.

**Window - As Needed**

Clean using a proprietary glass cleaning solution or a mild detergent, and wipe dry. Use only soft, lint-free cloths for glass cleaning. Never use an abrasive cleaner.

**Projector**

Review the manufacturer's instructions for proper maintenance of your projector/projector. Remember, the enclosure simply protects the equipment inside it and is not a substitute for regular maintenance.

## **7 Troubleshooting**

This is a guide to the general symptoms, problems, and solutions that may occur during the usage of your enclosure. However, it is important to remember that problems may occur within the projector itself and these must also be considered.

### **Projector does not have power.**

Check power supply wiring and voltage.

### **Fan is not spinning**

Fan cords may have become disconnected. Check connections between fan and cord.

Fan may be obstructed. Shut off power to enclosure and check for obstructions. Turn power back on to see if fan will start spinning. If fan does not turn then enclosure is not receiving power.

Turn off all power and check wiring. If the wiring is correct, contact technical support.

### **Projector does not have power.**

Check projector power switch. If switch is on, check wiring and supply switch/circuit breaker.

### **Projector turns on and off repeatedly over short span of time.**

Check that vent areas and airways are clear. If so, ambient temperature may be too high, or projector may have internal problem.

### **Excessive water in enclosure.**

Glass seal leak. Repair with silicone sealant.

Door gaskets leak caused by separation. Silicone piece back into place or replace section.

## 8 Limited Warranty

### INSPECTION/WARRANTY/RETURNS.

A. Customer, at its sole expense, shall inspect all Goods promptly upon receipt and accept all Goods that conform to the specifications or catalog. All claims for any alleged defect in or failure of the Goods or Seller's performance to conform to the Contract, capable of discovery upon reasonable inspection, must be set forth in a written rejection notice detailing the alleged non-conformity, and be received by Seller within thirty (30) calendar days of Customer's receipt of the Goods. Failure by Customer to notify Seller of the alleged non-conformity within thirty (30) days will be conclusive proof that the Goods have been received by Customer without defects or damage, and in the quantities specified on the bill of lading and shall constitute an irrevocable acceptance of the Goods and a waiver of any such claim in connection with the Goods.

B. Seller warrants to Customer only that the Goods will be free from defects in material and workmanship at the time of delivery and, subject to the exceptions and conditions set forth below, for the following period (the "Warranty Period"): twelve (12) months from the date of shipment by Seller. Seller may provide additional years of warranty coverage beyond 12 month, at the rate of 2.5% of the net sale price per year, up to a total of four additional years' coverage beyond the standard 12 month warranty period. Seller will remedy a defect as set forth in paragraph 7 D, below, (the "Warranty"). The Warranty is subject to each of the following exceptions and conditions:

1. Customer must promptly (and in all events within the Warranty Period) notify Seller of any alleged defect in a written notice (the "Notice") which shall set forth the quantity, catalog number, finish, original purchase order number, Seller's invoice number on which Goods were originally billed and a statement of the alleged defect, along with digital photographs showing such defects where feasible.

2. The Warranty shall not apply: (i) to any claimed defect that was capable of discovery upon reasonable inspection and deemed to be waived under paragraph A, above; (ii) to any Goods that have been subject to misuse, abnormal service or handling, or altered or modified in design or construction; (iii) to any Goods repaired or serviced by any person other than Seller's authorized service personnel or to Goods installed other than according to installation instructions, or (iv) with respect to normal wear and tear.

3. Seller makes no Warranty with respect to parts or components that are not the product of Seller, and specifically makes no warranty whatsoever for equipment housed inside enclosure products manufactured by Seller.

4. The Warranty is Seller's exclusive warranty with respect to the Goods. Seller makes no warranties, guarantees or representations, express or implied, to Customer except as set forth in this section. ALL OTHER WARRANTIES, EXPRESS OR IMPLIED, INCLUDING, WITHOUT LIMITATION ANY IMPLIED WARRANTY OF MERCHANTABILITY OR OF FITNESS FOR USE OR FOR A PARTICULAR PURPOSE, ARE HEREBY EXCLUDED AND DISCLAIMED.

C. Seller will accept the return of Goods properly rejected under paragraph A, above, or as to which Notice of an alleged breach of Warranty has been timely given and such Goods may be returned to Seller, freight prepaid, but only upon Customer's receipt of Seller's written return material authorization ("RMA") and shipping instructions. The RMA shall be void if the Goods are not received within 45 days after issuance of the RMA. No deduction or credit in respect of any rejected or returned Goods shall be taken until Customer has received Seller's further written deduction or credit/authorization following Seller's inspection to confirm nonconformity or defect. Seller will charge to Customer any and all costs incurred by Seller in connection with the handling, shipping, inspection and disposition of any returned Goods that are determined by Seller not to have been nonconforming upon Delivery or as to which the warranty hereunder is not applicable.

D. UPON ANY PROPER RETURN PURSUANT TO PARAGRAPH C, ABOVE, WHETHER IN CONNECTION WITH A REJECTION OF GOODS OR AN ALLEGED BREACH OF WARRANTY AND BASED UPON THE CONDITIONS SET FORTH IN THIS PARAGRAPH 7, SELLER AGREES THAT IT WILL, AS THE SOLE AND EXCLUSIVE REMEDY UNDER THE CONTRACT OR OTHERWISE, FOR ANY NONCONFORMITY OR BREACH OF WARRANTY, AND AT SELLER'S SOLE ELECTION: (i) REPAIR SUCH GOODS; OR (ii) REPLACE SUCH GOODS.

### Tempest Product Support.

Step 1: First contact your local Dealer for support. Your dealer is best placed to respond quickly to your needs.

Step 2: If your dealer is unable to answer your questions please contact our Sales Office:

Tempest Lighting, Inc.  
13110 Saticoy Street  
North Hollywood, CA 91605, USA  
Tel +1 818 787 8984  
Fax +1 818 982 5582  
[support@tempestlighting.com](mailto:support@tempestlighting.com)

Visit our web site for current information and specifications:

[www.tempestlighting.com](http://www.tempestlighting.com)

## 9 *Registration*

Filling out the registration form on the next page and sending it to the Tempest Lighting factory within 30 days of installation entitles you to the warranty cover specified in this manual. It also enables us to notify you in case of important news or post-sale information regarding the Blizzard Lighting Enclosure.

## ***Blizzard Enclosure Registration Form***

Detach and mail/fax to:

Tempest Lighting, Inc., 13110 Saticoy St., N Hollywood, CA 91605

Fax # +1 818 982 5582

If a Tempest Representative has not inspected the installation, please send photos showing installation.

Model Number: .....

Serial Number: .....

Padlock Key Number: .....

Dealer/Sold By

Name: .....

Location: .....

Date Purchased: .....

Contractor/Installed By

Name: .....

Date Installed: .....

Location Installed: .....

Company/Organization

Name: .....

Street Address:  
.....

City, State, ZIP, Country:  
.....

Phone: .....

Fax: .....

Contact Information

Name: .....

Phone: ..... Extension: .....

Fax: .....

E-mail: .....

## Appendix:

### DEC3 Control – Enclosures manufactured before Sept. 2011

**IMPORTANT** Tempest enclosures are supplied for either 120VAC 50/60Hz, or 208-240VAC, 50/60Hz operation. Tempest Lighting is not liable for damage or failure to operate correctly due to connection to an inappropriate electrical supply.



**ALL ELECTRICAL CONNECTIONS MUST BE UNDERTAKEN BY A QUALIFIED ELECTRICIAN, IN COMPLIANCE WITH LOCAL NORMS AND STANDARDS.**

#### Split or Common Supply Wiring

**NOTE:** *Your enclosure MUST run 24/7, in order to protect equipment from condensation and temperature extremes.*

Tempest Enclosures are supplied wired for common electrical supply for the enclosure (DEC3) and the projector/light fixture to be enclosed. Customers wishing to provide independent electrical feeds to the enclosure and the projector/fixture must follow the instructions below.

#### Feeder Connections – Common Feed

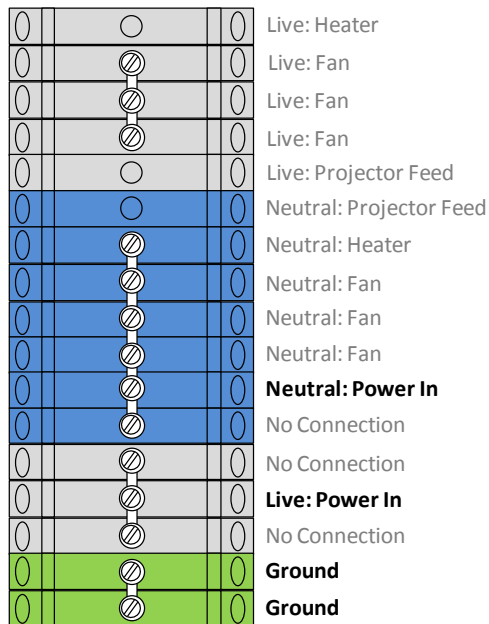

#### Feeder Connections, Split Feeds

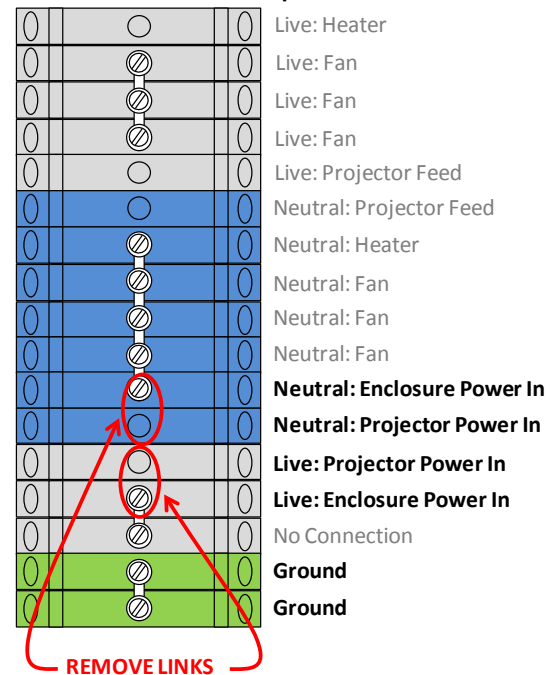

Note: terminals shown with gray text descriptors are factory wired and should not be changed. Only terminals shown with descriptors in black/bold font are for installer use.

DEC3 normally ships from the factory with power terminal links inserted for a common electrical supply to feed the enclosure and the projector/fixture inside it.

If you prefer to feed the enclosure and projector separately, remove the terminal links as indicated before connecting to mains power. Use a small flat-bladed screwdriver to remove the link, snap off the unneeded section and replace carefully. When splitting the feeders, we strongly recommend feeding both supplies from the same phase and at the same supply voltage.

### ***3.1 DMX Connections***

DMX refers to USITT DMX512, a commonly used control protocol in the entertainment industry, running over RS485. Consult USITT DMX installation guidelines when laying out a system, or consult a qualified DMX system integrator.

Note that DMX is optional - in many applications it is not required, and need not be connected. For more information, see DEC3 Operating Modes in the next section.

**DMX IN** - Connect incoming DMX to the 2-part 3-pin terminal on the DEC3 control circuit board so labeled.

Pinout: (1) Ground, (2) Data -, (3) Data +.

**DMX THRU** - there are two DMX pass-through terminals - one for a fixture inside the enclosure, the other to run to the next DMX device in the network.

Pinout: (1) Ground, (2) Data -, (3) Data +.

## DEC3 Control – Introduction

Tempest Lighting and Projector Enclosures have been in daily use around the world for almost a decade. Tempest enclosures protect expensive and delicate equipment in all climates, maintaining a comfortable operating temperature, and preventing condensation – the real outdoor enemy.

DEC3™ – that’s *Digital Enclosure Control, third Generation* – is the brain of your Tempest enclosure. It will maintain the internal environment in a comfortable temperature and humidity range, and prevent condensation – the real equipment killer. DEC3 monitors internal temperature, humidity and lamp current at all times, and uses this information to control its lamp relay, fan(s) and heater(s). It can report back over the DMX cable, using the RDM protocol (Remote Device Management) if desired.

Unless otherwise specified, this version of the user guide refers to DEC3 units fitted with software version 2.1 or later.

### So, what does DEC3 actually DO?

DEC3 is the brains of the operation – here’s a layout:

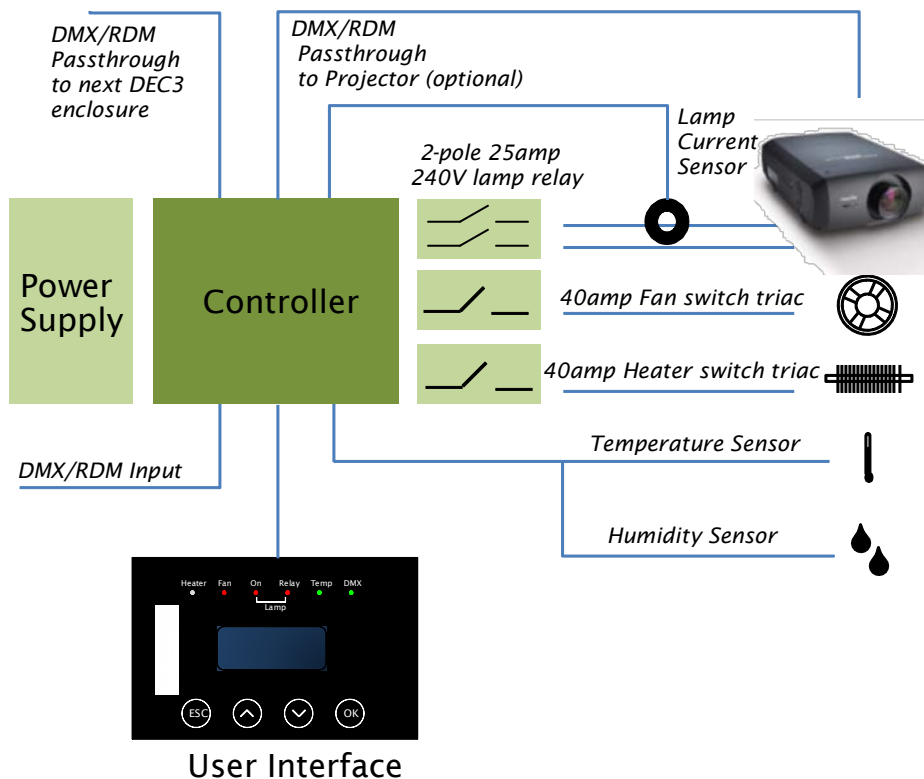

*This schematic shows the relationship between DEC3’s functional elements. The power supply is universal 90-260V, but fans and heaters are either 120V or 230VAC, and must be so specified. A high-quality 25amp 2-pole electro-mechanical relay isolates fixture/projector power in the event of an over-temperature condition. Fans and heaters are switched using generously overrated 40amp Triac devices for maximum reliability. Two DMX outputs connect to the internal fixture (if desired) and on to other enclosures or DMX devices.*

DEC3’s mission is to maintain temperature and humidity inside the enclosure, within determined bounds, and to prevent condensation – particularly overnight dew formation – inside the equipment housed. Condensation is fatal to electronic equipment, particularly in polluted areas or saline environments, where it brings not only rust and short-circuits, but also a steady buildup of mineral and/or salt deposits. Incidentally, condensation is very hard to control with air-conditioning type systems, which is why we don’t use them.

Broadly speaking, DEC3’s function depends on whether the fixture/projector lamp is on or off:

### **Lamp ON**

When the projector/fixture is running, the heat from the lamp takes care of humidity, and DEC3 runs the enclosure's fan(s) to change its air every few seconds - ensuring minimal temperature rise above outside ambient.

### **Lamp OFF**

When the lamp is off, DEC3 senses temperature and humidity and controls its fan(s) and heater(s) accordingly. When conditions are within normal bounds (between top and bottom temperature settings and below the humidity threshold (see below), DEC3 pulses the heater at a low level to dry the air and eliminate condensation, and runs the fans to change the enclosure air every 30 seconds or so. We call this 'pulse mode', and it is the key to preventing damaging condensation inside your equipment.

If the temperature rises above the top set limit (see below), DEC3 runs the fans to cool it down. In cold conditions, DEC3 will run the heater as required to maintain the bottom set temperature.

Thus, DEC3 maintains a comfortable operating temperature inside the enclosure, and prevents damage from condensation. Users all over the world have found that Tempest enclosures provide an optimal environment for expensive and delicate equipment, in every climate type.

And while doing all of this, DEC3 can tell you what's happening over your RDM network - a real boon in larger installations.

## *Operating Modes*

DEC3 may be run in one of three basic operating configurations. A fourth configuration is provided for test and service use.

**Standalone:** The enclosure operates independently, and automatically, requiring no user intervention. User may set parameters such as temperature and humidity thresholds, and monitor sensor information and DEC status at the DEC3 user interface. Standalone is the default DEC3 shipping mode unless specified otherwise at time of order. DMX is not required or utilized.

### **DMX/RDM Mode 1 (RDM Monitor)**

All of the Standalone features plus the ability to discover and monitor the DEC3 over a DMX512 connection, using RDM.

In this mode, the DEC3 does not need to “see” any DMX to operate. The mode allows the use of RDM to set the various temperature thresholds, and monitor the conditions inside the enclosure remotely. The fixture inside the Tempest enclosure may also be an RDM enabled device.

### **DMX/RDM Mode 2 (DMX Enable)**

All of the Standalone and RDM Monitor features plus the use of a single DMX address (slot) to control the Lamp Relay.

This means that the user is responsible for maintaining a DMX input with the slot (as selected as the DMX START ADDRESS on the DEC3) high. This slot level must be set greater than 50% at all times when the internal fixture is to be powered. This has the useful attribute of enabling the user to remotely force a hard reset of the fixture by opening and then closing the Lamp Relay. It also means that it is unnecessary to feed the enclosure with two power sources (for the enclosure and the luminaire/projector), since the DMX slot may be used to isolate the projector when not in use, without removing power from the enclosure. This mode is recommended for show-control applications, where it is desirable to have power control of the internal fixture, and accidental loss of the DMX data is very unlikely to occur.

In the absence of DMX, the Lamp Relay defaults to “ON”.

All RDM functions are available for configuration and monitoring of the DEC3.

### **DMX/RDM Mode 3 (Service/Test)**

This mode is intended for test and service use.

It gives the user direct control of the lamp, fan and heater relays over DMX. User may NOT override any of the relays in an unsafe direction – for example, if the DEC3 has determined the enclosure is over-temperature and has switched off the lamp relay, the relay may not be overridden ON by DMX. In this sense, DMX ‘piles

on' to DEC3 operation, within defined safety limits. However, until such time as the temperature reaches the TOP limit, the heater may be enabled and the fan disabled, which is why the mode should only be used for Test and Service use.

If the DEC3 has been purchased with DMX/RDM enabled, it is possible to select the required mode 1-3 using RDM. In the RDM context, this is known as selecting the device's DMX PERSONALITY. Setup of the DEC3 from the Front Panel is available in all configurations.



RDM is an effective and powerful tool for commissioning and monitoring an installation, particularly in large systems. For further guidance, we recommend you consult a qualified RDM system integrator. If you don't have one in your neighborhood, go to [www.tempestlighting.com](http://www.tempestlighting.com), and click on the RDM and RDM Integration bug on the home page for some useful contacts. Tempest Lighting warrants DEC3 to be compliant with the RDM standard, but is not an RDM systems integrator, and can offer only basic guidance on RDM utilization.

## DEC3 Control Parameters

DEC3 will run out of the box with its default parameter settings, which equate to the (fixed) settings of its predecessor DEC1 and 2.

Temperature:

Top Set	<p><i>Range 35-45°C, Default = 40°C</i></p> <p>Most manufacturers recommend a max temperature for their equipment of 40°C, though this does vary. When DEC3 senses a temperature higher than Top Set, it indicates an overtemp condition as a warning. NOTE: in moving light enclosures the thermal sensor is necessarily placed in the exhaust air path, which will be higher (sometimes a lot higher) than the actual fixture ambient. This needs to be kept in mind when adjusting temperature settings.</p>
Cutoff Temp	<p><i>Range 0-15°C, Default = 15°C</i></p> <p>This is a setting <i>above</i> the Top Set temperature that determines the temperature at which the lamp relay is opened, cutting off power from the fixture/projector. The user may reduce it as desired, but should establish before doing so the actual operating temperatures experienced in hot weather before doing so, to avoid nuisance tripping.</p>
Bottom Set	<p><i>Range 0-10°C, Default = 10°C</i></p> <p>The temperature maintained by the heater in cold conditions. Most equipment manufacturers recommend a minimum</p>

operating temperature of 0°C, and users may set it lower than the default if desired.

- Humidity      Range 50-90%, *Default 80%*  
The threshold at which incoming air is more aggressively heated to remove moisture. This parameter will not normally require adjustment.
- DMX Set      *Range 001-510, Default 001*  
Sets the DMX address for the lamp relay control. In the DMX/RDM service mode, the subsequent two DMX slots control fan and heater respectively.
- Lamp Hours    *Default 0000*  
DEC3 counts the hours your projector/fixture lamp is on, and can report it both on the user interface display and over RDM. ***Remember to reset to 0 when changing lamps.*** This is provided to allow lamp hours monitoring on devices such as Video Projectors and certain moving lights that have no native RDM or DMX support.

## Setup and Connections

### Operating Mode Setup

Your DEC3 will normally be factory set to the operating mode you specified in your order:

#### Operating Mode DIP Switch Settings

Mode	DIPswitch Settings	Mode Summary
Standalone	1-6 OFF	Standalone – no DMX/RDM
DMX/RDM	2 ON, 1, 3-6 OFF	DMX/RDM Modes 1-3 – support for remote monitoring

### DMX Connections

DMX refers to USITT DMX512, a commonly used control protocol in the entertainment industry, running over RS485. Consult USITT DMX installation guidelines when laying out a system, or employ a qualified DMX system integrator.

Note that DMX is optional – in many applications it is not required, and need not be connected.

**DMX IN** – Connect incoming DMX to the 2-part 3-pin terminal on the DEC3 control circuit board so labeled.

Pinout: (1) Ground, (2) Data -, (3) Data +.

**DMX THRU** – there are two DMX pass-through terminals – one for a fixture inside the enclosure, the other to run to the next DMX device in the network. Pinout: same as DMX IN.

### DMX Line Terminations

DMX cable runs must be terminated at the far end of the cable run with a termination resistor as detailed in the DMX standard. This is particularly important for satisfactory operation of DMX/RDM installations. The individual fixtures installed inside the Tempest enclosures must NOT be terminated. It is recommended that any line termination is done using the 3-pin terminal connector fitted to the DEC3 control circuit board.

1. Make sure that any DMX termination provided by the fixture inside your enclosure(s) is disabled.
2. The LAST enclosure in the installed DMX daisy chain should have a DMX Termination fitted to one of the pass through DMX connectors. Per the ANSI E1.11 standard, the Terminator shall be 120 ohm +5%/-10% impedance placed between Data+ and Data-. We recommend minimum power rating of 0.6W for the resistor.  
We recommend that the installer fit a label externally to say “DMX Termination fitted internally”.

Test:

3. Switch mains power OFF to all enclosures.
4. Before connecting the DMX line to your controller, measure the impedance between Pin 2 (Data-) and Pin 3(Data+) at the controller end. Reading should be around 100-130 ohms.

This test shows that you have a terminator in place, and also that you have continuity of Data- and Data+ between installed devices. If the measured resistance is significantly less than 100 ohms, (say 40-80 ohms) it suggests you may have multiple terminations in place. Check that any terminator switches on light fixtures are OFF. If impedance is very low, check for wiring shorts.

## *RDM Connections*

RDM refers to ANSI E1.20, a control protocol in the entertainment industry gaining popularity and essentially an “extension” of DMX512. The use of RDM is optional – but it does require a DMX512 cable connection.

## *Important – RDM and RDM Integration*

RDM (Remote Device Management) is an ANSI standard that adds bidirectional discovery and status monitoring to a standard DMX network connection. No additional wiring is required for RDM operation.

DEC3’s RDM implementation allows system integrators to set up remote control and status monitoring of all attributes and sensors, including:

- Temperature
- Humidity
- Lamp Current
- Elapsed Lamp Hours
- Lamp Relay Status
- Fan Relay Status
- Heater Relay Status
- DMX Status
- DMX Start Address
- DMX Personality (RDM Mode)
- Device Type
- Device Label
- Software Version

Tempest Lighting warrants that its RDM products are compliant to the RDM standard, but does not directly support RDM system integration. Tempest Lighting will however provide introductions to qualified RDM system integrators for customers requiring assistance in this area. Links are provided on the Tempest Lighting web site ([www.tempestlighting.com](http://www.tempestlighting.com)).

## Control Interface

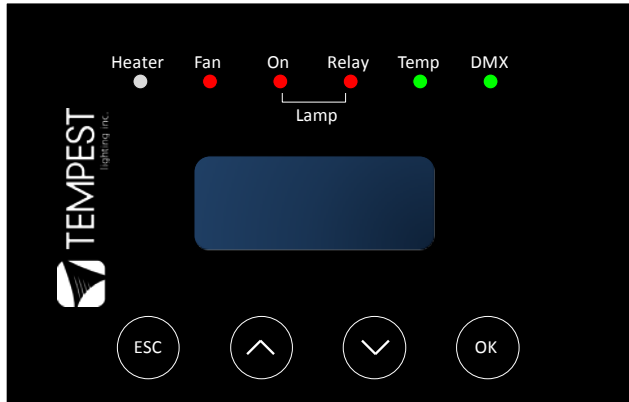

The control interface features a 2-line display, LED indicators, and 4 cap-sense control buttons.

### LED Indicators

#### Heater

SHORT PULSE (RED) - Indicates lamp is off, and the heater is pulsing to prevent condensation inside the enclosure and projector/light fixture. This is normal operation when the lamp is off and the temperature range is above the bottom set limit.

ON (RED) - Indicates heater is on, due to temperature being below bottom temperature setting when lamp is off.

OFF - indicates lamp is on and maintaining temperature above bottom limit.

#### Fan

SHORT PULSE (RED) - The fan is moving a little air through the enclosure, as part of the condensation prevention strategy. The fan comes on for a few seconds approximately every 30 seconds.

ON (RED) - Indicates fan is running, due to lamp being on or internal temperature exceeding top limit.

#### Lamp Relay

ON (RED) Indicates lamp relay closed and power is available to the internal fixture/projector.

OFF Indicates lamp relay open and power is removed from the internal fixture.

#### Lamp On

ON (RED) Indicates current sensed on the lamp circuit greater than 1 amp (this allows some current to be drawn for such things as fans and control electronics without the Lamp On indicator lighting. When the Lamp On indicator is on, the lamp counter is counting lamp life.

#### Temp

ON (GREEN) - The temperature is between Bottom and Top temperature settings.

FLASHING (RED) - The temperature is above Top setting but has not yet reached the Cutoff level.

ON (RED) - Temperature is above Cutoff level or below Bottom level.

DMX (only used when DMX/RDM setting is in effect)

ON (RED) - DMX error.

ON (GREEN) – Good DMX or RDM data packet received.

## Control Interface Operation

The Control Interface is normally LOCKED.  
 To UNLOCK, touch ESC and OK together for 5 seconds.  
 You are now in the CONTROL MENU  
 Use the arrow keys to scroll up and down the menu.  
 Use OK, to enter a menu item, then the arrow keys to set the item parameter, or to scroll to the next menu level.  
 Use ESC to back up a level, and OK to confirm settings.

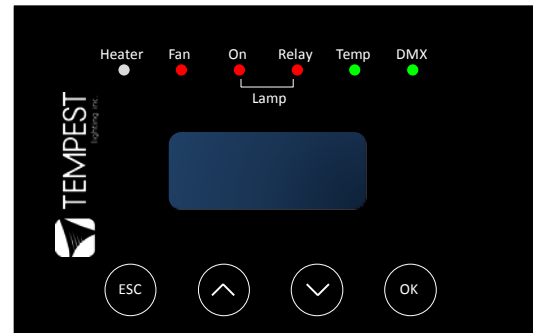

*Depending on the Operating Mode selected, and present status, DEC3's display shows you temperature, humidity, DMX address and a selection of error and status messages.*

### CONTROL MENU

#### DMX SET (if DMX/RDM mode 2 or 3 is selected)

Select a DMX starting address in the range 001 to 510

1 – Lamp Relay

In RDM Mode 3 an addition two slots are required

2 – Fan Relay

3 – Heater Relay

*Note that the DMX control is designed using a SAFETY pile-on Logic. In other words, the DMX input can only override automatic settings in a safe manner. For example, if the enclosure has switched off the lamp relay due to an over-temperature condition, the DMX input cannot switch it on, if the fans are running because of Overtemp, the DMX input cannot turn them off, and so on.*

*The DMX SET menu can be ignored if the DEC3 is in Standalone or DMX/RDM Mode 1 (RDM Monitor) mode.*

#### SET LAMP HOURS TO 0

The lamp hour counter needs to be reset each time you change the lamp in the fixture/projector. Make this a part of your maintenance instructions.

#### STATUS DISPLAY

View Temperature (in Celsius) and Relative Humidity (in %) inside the enclosure. Note that in Tornado moving light enclosures the temp/humidity sensor is located in the exhaust airflow, which may be significantly warmer than ambient.

#### HUMIDITY SET

The humidity level above which the heater kicks in to remove humidity from incoming air (default 80%, permissible range 50-90%). This setting should not normally be changed.

#### TEMP SET

Set three temperature trigger points for Top, Cutoff and Bottom temperatures.

##### TOP TEMP

The desired upper temperature limit for normal operation (default 40°C, permissible range 35-45°C).

When the DEC3 sees air above this temperature, but below the additional Cutoff temperature (see below), it indicates a temperature error. This is not dangerous, but may reduce lamp life.

#### **CUTOFF TEMP**

The desired upper temperature ABOVE the TOP TEMP setting, at which the lamp relay is forced to open, isolating the fixture/projector power.

(default 15°C, permissible range 0-15°C).

To avoid nuisance tripping, set this variable to the maximum, and monitor actual temperatures in your normal operating conditions. If your actual temperatures are running lower, then you may reduce the cutoff temperature margin. In hot climates, it may be advisable to set both TOP TEMP and CUTOFF TEMP as high as possible.

#### **BOTTOM TEMP**

The desired lower temperature limit for normal operation

(default 10°C, permissible range 0-10°C).

Note that a higher BOTTOM TEMP may provide additional protection against condensation in some conditions, but will consume more energy. Therefore a lower setting is desirable, provided the user is certain that no condensation is occurring.

#### **RDM MODE SET**

The RDM Mode is normally set using RDM commands from a remote RDM control device to set the DMX PERSONALITY of the DEC3.

From the DEC3 user interface, this menu item allows the user to check (and if necessary alter) the RDM mode. Please ensure that the DEC3 is NOT unintentionally left in Mode3 (Service/Test).