

User Manual and Installation Guide



Hurricane 1000 Series Enclosures, DEC3.2 and up



September, 2011



You can download a copy of this manual at
<http://www.tempestlighting.com/products.html#Hurricane>

Tempest Lighting, Inc.
13110 Saticoy Street, Unit # C
N. Hollywood, CA 91605, USA

Tel +1 818 787- 8984
Fax +1 818 982- 5582
info@tempestlighting.com

In the interest of continuous product improvement, the information in this document is subject to change without notice. Neither Tempest Lighting, Inc. nor its representatives or agents may be held liable for expense or injury arising from it.

© Tempest Lighting Inc. All Rights Reserved



Declaration of Conformity

This is to certify that the following product:

1000.IN Hurricane 1000 Enclosure, 230V

is in Compliance with the following standards or specifications according to the EMC Directive 89/336/EEC.

EN55015, EN61000-3-4, EN61000-3-5, EN61000-4-2, EN61000-4-3, EN61000-4-4, pr EN61000-4-5, EN61000-4-6, EN61000-4-8, EN61000-4-11

and is in compliance with the following standards or specifications according to the Low Voltage Directive 73/23/EEC.

EN60598-1

This declaration is made by the manufacturer

**Tempest Lighting, Inc.
13110 Saticoy Street, Unit C**

North Hollywood, USA

This declaration is based on tests that were conducted on the submitted samples of the above mentioned products. Detailed results can be referred to test reports CET.TE200909 and LVT.Te200909.

Dated: March 24th, 2010

Signature 

Tempest Lighting Inc



Tempest Lighting, Inc.,
13110 Saticoy Street, Unit C, North Hollywood, CA 91605, USA
www.tempestlighting.com info@tempestlighting.com
t: +1 818 787 8984
f: +1 818 982 5582

Table of Contents

Topic	Section
Introduction.....	1
INSTALLATION.....	2
Safety and Warnings.....	2.1
Mounting the Enclosure.....	2.2
Orientation.....	2.3
Drainage Holes.....	2.4
Dimensions and Layout.....	2.5
Wiring.....	3
Electrical Preparation.....	3.1
Digital Enclosure Control.....	3.2
AC Connections.....	3.3
DEC3.2 Control.....	4
Operating Modes.....	4.1
DEC3 Control Parameters.....	4.2
Operating Mode Setup.....	4.3
DMX Connections.....	4.4
DMX Line Termination.....	4.5
RDM Connections.....	4.6
RDM Integration.....	4.7
Control Interface.....	4.8
Control Interface Operation.....	4.9
Mounting the Projector.....	5
Activation and Checkout.....	6
Operation.....	7
Routine Maintenance.....	8
Troubleshooting.....	9
Sample Specification Boilerplate.....	10
Warranty.....	11
Support.....	12
Registration.....	13
DEC 3 Control.....	Appendix

1 Introduction

The Hurricane™ Scanner Enclosure

Thank you for purchasing the Hurricane Lighting Scanner enclosure. Although originally intended for outdoor environments, the design of the Hurricane is such that it can satisfy many other needs. Not only will it protect against hostile outdoor conditions, but also against particulate, smoke, and other indoor conditions that can shorten the life of your high-output Lighting Scanner.

Using This Manual

This manual covers all Hurricane Models in the 1000 product series. Please read it in its entirety before starting work. All the information contained is important, and should be read carefully before proceeding. Heed all warnings and advisories.









Icon Key:

- ① Valuable information
- ⚡ Electrical Warning
- ⚠ Safety Information

2 Installation





2.1 Safety and Warnings

These warnings are for your protection. Failure to comply may result in serious injury or death. Manufacturer assumes no responsibility for damages or injury incurred by misuse or mishandling of product.

-  **Do not** attempt to install or operate the enclosure before fully reading and understanding this manual
-  **This enclosure is HEAVY – do not attempt to lift with fewer than two people.**
-  **Never** allow anyone who has not read this manual to open the enclosure or perform maintenance on the luminaire within.
-  **Never** leave the enclosure unattended when open.
-  Even after power has been disconnected from the enclosure, the internal heater may remain warm. Do not touch it unless you can be sure that the power has been off for at least one hour.
-  **Always** make sure all bolts are tight and safety cables are in place after performing any form of maintenance on the unit.
-  **Observe** all posted warnings in the enclosure itself.
-  **Do not** open any electrical boxes until power has been shut off to all supply lines to the enclosure (including the one powering the projector).
-  **Do not** open the enclosure in wet weather.

Tools and Equipment

To install the enclosure, you will need the following items:

-  Crescent wrench
-  Phillips screwdriver
-  Proper wiring installation equipment (for line power and DMX)
-  Any equipment listed in the fixture manufacturer's fixture-specific installation directions

2.2 Mounting the Hurricane Enclosure

- ① The Hurricane enclosure may be mounted horizontally or vertically, on a solid structure, truss or equivalent, rated for the weight of the enclosure and any equipment housed inside it.
- ① Snow - if installed outside in cold regions, the lowest part of the Hurricane enclosure must be at least 2' (60cm) above maximum height of any snowfall or drifting snow, subject to local conditions. If snow is not a consideration, then the enclosure must be installed at least 12"/30cm above ground level and maintained clear of drifting leaves and other potential blockages to good drainage.
- ① Enclosure will need to be powered at all times, although projector may not be.
- ① LEAVE ADEQUATE CLEARANCE AROUND ENCLOSURE TO OPEN TOP COVER FOR SERVICE
- ① *Tempest Lighting recommends the use of stainless steel mounting hardware.*

The Hurricane enclosure is provided with a pair of Unistrut channels under the enclosure base, for mounting to your structure. You may use standard Unistrut accessories, or purchase either of the mounting kits available from Tempest Lighting – four kits are required per enclosure.

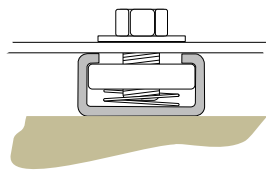

4900.MB *Stainless Steel Unistrut channel nut, bolt and washer. Four required per enclosure.*

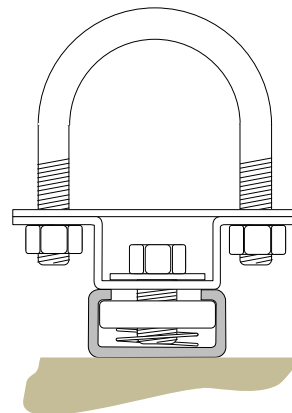

4900.MC *Stainless Steel Unistrut channel nut, bolt and pipe clamp, for pipes 1.5" (38mm) to 2" (50mm) OD. Four required per enclosure.*

4925.MC *Stainless Steel Unistrut channel nut, bolt and pipe clamp, for pipes 2" (50mm) to 2.5" (64mm) OD. Four required per enclosure.*

2.3 IMPORTANT: Orientation

Hurricane Enclosures may be mounted in the any orientation, subject to any limitations stipulated by the manufacturer of the projector housed inside it. You are advised to check the projector manufacturer's installation manually carefully before planning your installation.

2.4 IMPORTANT: Drainage Holes

When the enclosure is installed, drill two 1/4" (6mm) holes at the lowest point in the enclosure, to allow any water inside the enclosure to drain away. If the enclosure is mounted vertically, drill two holes in the bottom of the lower fiberglass cowl.

The NEMA 3R standard to which the enclosure is designed allows some water ingress, provided there is a drainage path for the water to escape. Small amounts of water will not cause any damage, provided they can drain away.

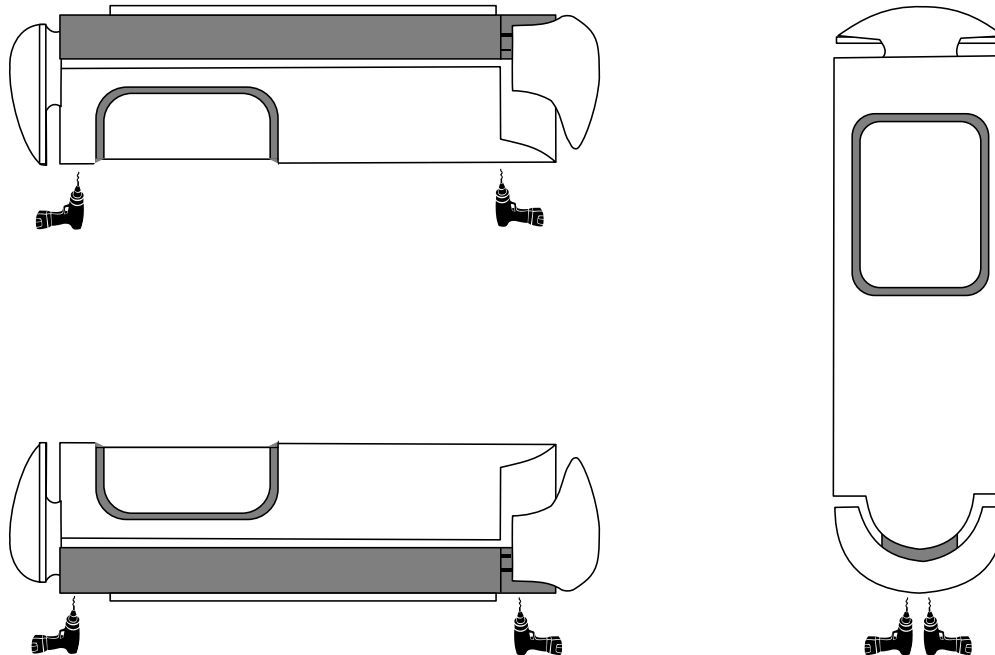

2.5 Enclosure Dimensions and Layout

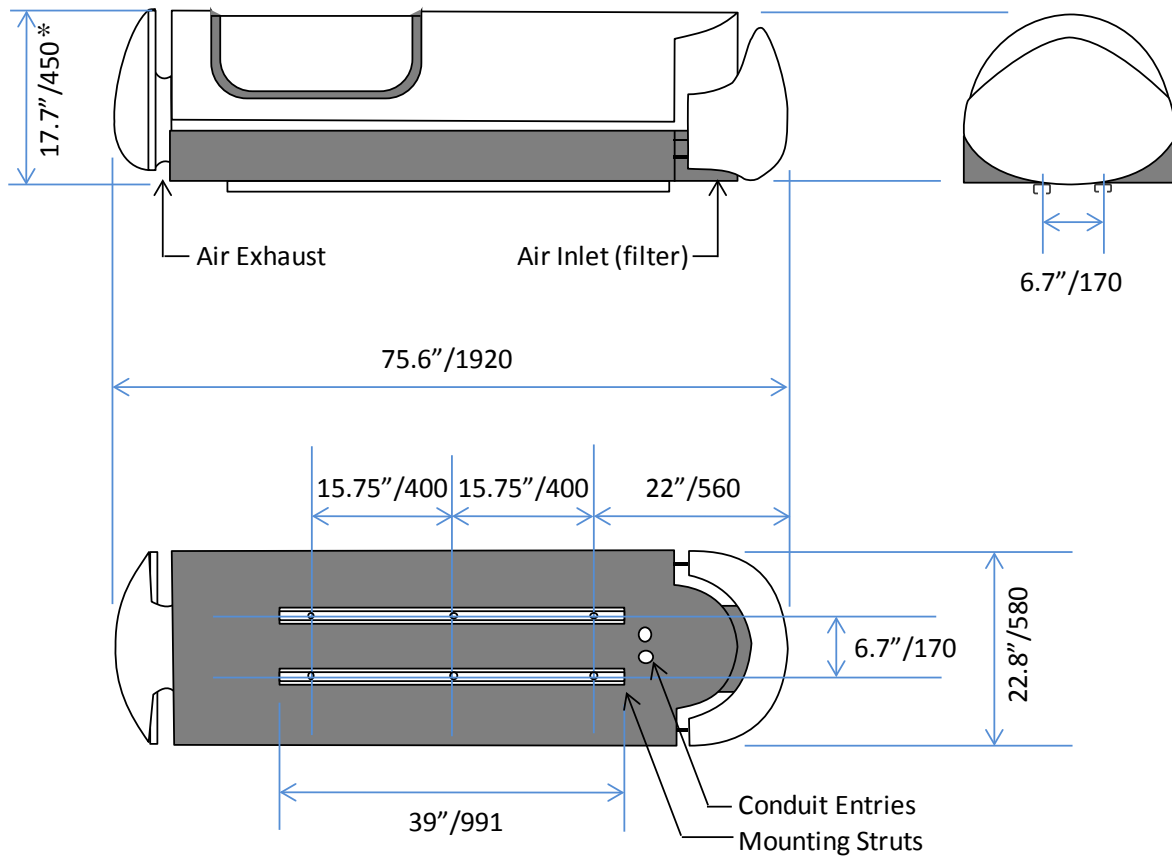

*** NOTE: Height increased from 17.7"/450mm to 18.7"/475mm, effective August 2011**

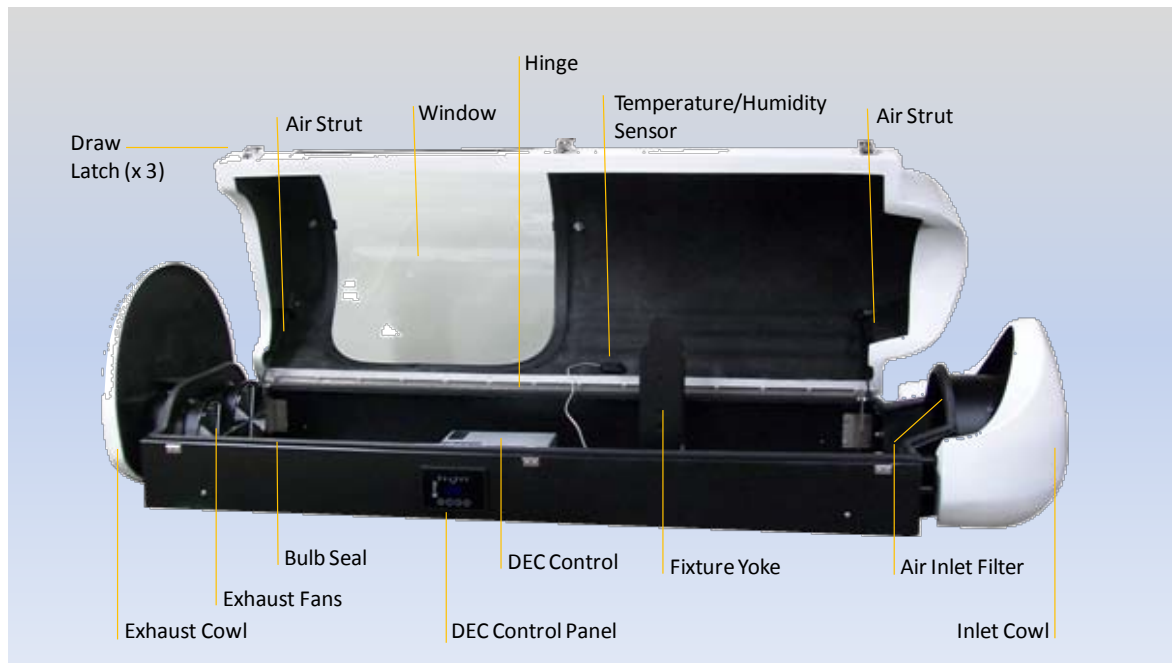

3 Wiring

3.1 Electrical Preparation

- ⚡ All electrical work must be carried out by a properly licensed electrician. Failure to observe this point will void the factory warranty for the Tempest Enclosure and possibly the luminaire/projector.
- 1 Before starting work, switch off power to the branch circuit, carefully following lockout and tag-out procedures. Failure to do so could cause serious injury or death.
 - 2 Two electrical junction boxes will be required within a short distance of the Hurricane enclosure for:
 - AC Supply wiring
 - DMX Control wiring

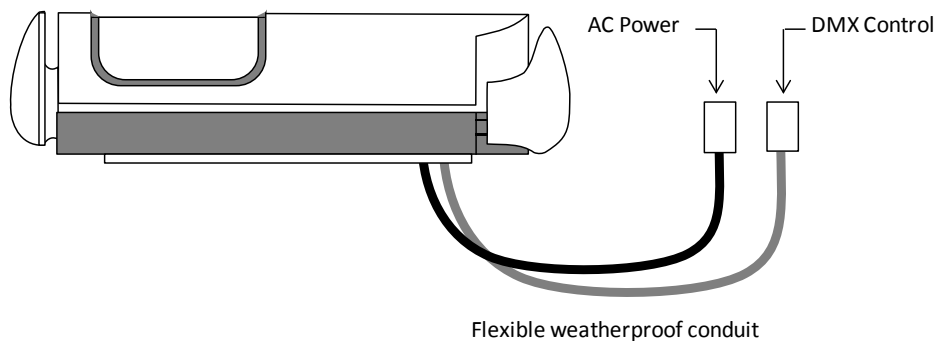

- 3 All junction boxes must be installed in accordance with local electrical codes and should be located near the permanent installation of the enclosure. Each junction box requires a length of 1/2" (20mm International) flexible weather-resistant conduit, long enough to reach from junction box to the enclosure conduit entries.
- 4 The AC supply must be 200-240VAC, and must be protected by a fuse or circuit breaker of a rating suitable for the projector, plus 650 watts max for the enclosure fans and heaters.
- 5 Connect the local junction box to the Hurricane enclosure using exterior grade flexible conduit. Pull suitably rated wires through the conduit to supply the Hurricane enclosure and connect as described below.
- 6 Alternatively, you may run separate AC feeds for the projector and the enclosure. Follow either single or double-feed wiring instructions below, according to preference:

3.2 Digital Enclosure Control

The Digital Enclosure Control (DEC3) system monitors power, data, temperature and humidity, and is the key to assuring long equipment life in your Tempest Enclosure. In the Hurricane enclosure, the DEC is located in the base, and is protected by an aluminum cover.

Remove the four nuts holding the cover in place to access the DEC for installation and setup.

Before installing the fixture in the Hurricane enclosure, replace the cover, taking care not to trap any wires.

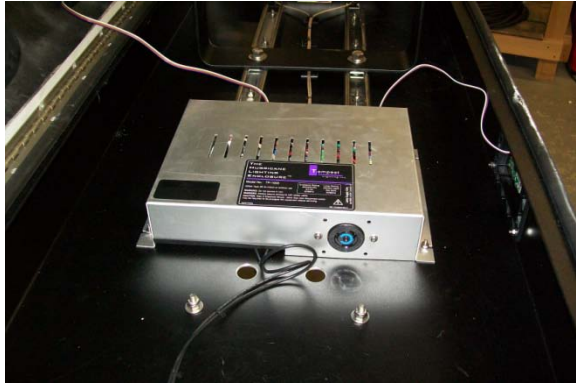

Digital Enclosure Control (DEC3) cover in place, showing US-Style L6-20 fixture receptacle (International version has a CE17 16amp receptacle).

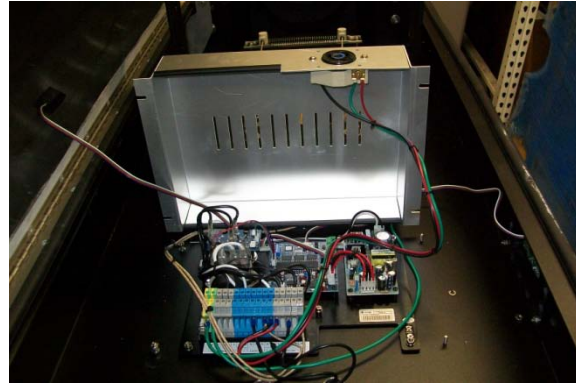

Digital Enclosure Control (DEC3) cover open, showing terminal block for power terminations.

Picture shows DEC3, which differs slightly in appearance from DEC3.2, shipping from September 2011.

DEC 3 or DEC 3.2?

IMPORTANT: Effective late August 2011, Tempest enclosures are shipping with the new, improved, DEC 3.2 control system.

If the control assembly in your enclosure looks like *this*:

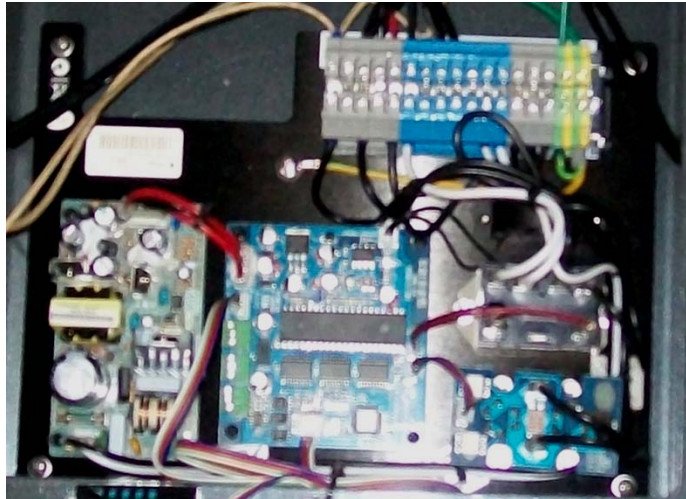

You have a DEC3 controller. Please go to the DEC3 appendix at the end of this manual.

Otherwise,

Digital Enclosure Control – DEC3.2™

Use the following section if your enclosure controller looks like *THIS*:



DEC 3.2 Control – Introduction

Tempest Lighting and Projector Enclosures have been in daily use around the world for almost a decade. Tempest enclosures protect expensive and delicate equipment in all climates, maintaining a comfortable operating temperature, and preventing condensation – the real outdoor enemy.

DEC3.2™ – that’s *Digital Enclosure Control, third Generation, revision 2* – is the brain of your Tempest enclosure. It will maintain the internal environment in a comfortable temperature and humidity range, and prevent condensation – the real equipment killer. DEC3.2 monitors internal temperature, humidity and lamp current at all times, and uses this information to control its lamp relay, fan(s) and heater(s). It can report back over the DMX cable, using the RDM protocol (Remote Device Management) if desired.

Unless otherwise specified, this version of the user guide refers to DEC3.2 units fitted with software version 0.1.xxx or later.

So, what does DEC3.2 actually DO?

The DEC3.2 Engine is the brains of the operation – here’s a layout:

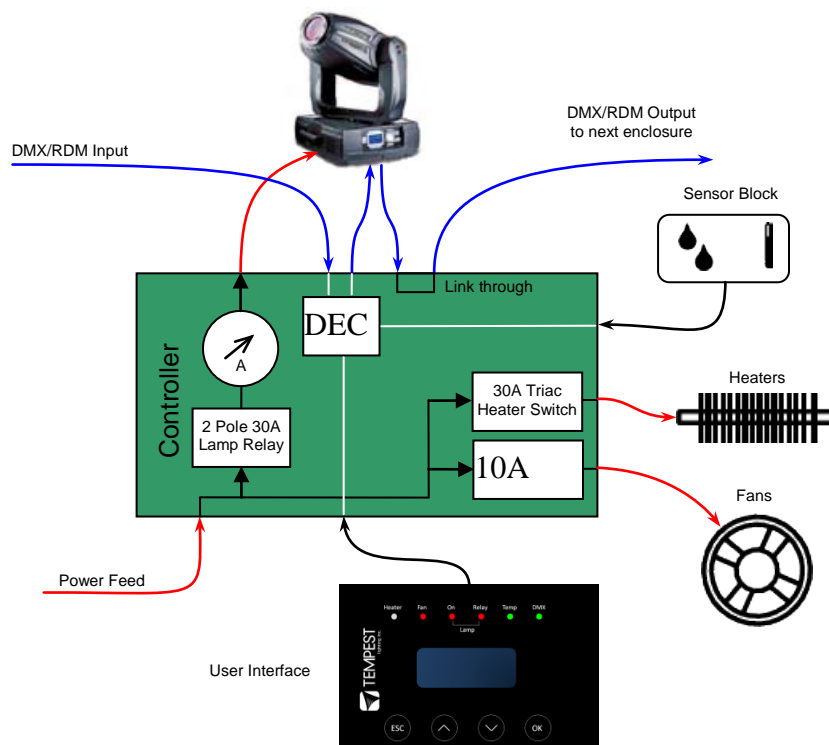

This schematic shows the relationship between DEC3.2’s functional elements.

The power supply is universal 100-240V, but fans and heaters are either 120V or 230VAC, and must be so specified.

High-quality, high power Electro-mechanical relays provide two pole power isolation for the enclosed the fixture/projector in the event of an over-temperature condition.

Fans and heaters are switched using generously overrated Triac devices for maximum reliability.

4 DMX connections are provided to facilitate field termination of DMX inputs and outputs via the enclosed fixture and the controller.

DEC3.2's mission is to maintain temperature and humidity inside the enclosure, within determined bounds, and to prevent condensation – particularly overnight dew formation – inside the equipment housed. Condensation is fatal to electronic equipment, particularly in polluted areas or saline environments, where it brings not only rust and short-circuits, but also a steady buildup of mineral and/or salt deposits. Incidentally, condensation is very hard to control with air-conditioning type systems, which is why we don't use them.

Broadly speaking, DEC3.2's function depends on whether the fixture/projector lamp is on or off:

Lamp ON

When the projector/fixture is running, the heat from the lamp takes care of humidity, and DEC3.2 runs the enclosure's fan(s) to change its air every couple of seconds – ensuring high-velocity forced-air cooling while the lamp is on.

Lamp OFF

When the lamp is off, DEC3.2 senses temperature and humidity and controls its fan(s) and heater(s) accordingly. When conditions are within normal bounds (between top and bottom temperature settings and below the humidity threshold (see below), DEC3.2 pulses the heater at a low level to dry the air and eliminate condensation, and runs the fans to change the enclosure air every 30 seconds or so. We call this 'pulse mode', and it is the key to preventing damaging condensation inside your equipment.

If the temperature rises above the top set limit (see below), DEC3.2 runs the fans to cool it down. In cold conditions, DEC3.2 will run the heater as required to maintain the bottom set temperature.

Thus, DEC3.2 maintains a comfortable operating temperature inside the enclosure, and prevents damage from condensation. Users all over the world have found that Tempest enclosures provide an optimal environment for expensive and delicate equipment, in every climate type.

And while doing all of this, DEC3.2 can tell you what's happening over your RDM network – a real boon in larger installations. You may also use RDM to configure your Tempest installation remotely, using an appropriate RDM front end.

Default Operation

In most lighting and in almost all projector enclosure applications, DEC3.2 will work just fine with its factory default settings. *You do not need to do anything* other than connect power and switch on. We call this *Basic mode*, and it will apply to most installations. If your needs are more complex, read on.

If not, you can skip to the Power Connections section below.

Operating Modes

DEC3.2 may be run in one of three basic operating configurations with a fourth configuration for test and service use by trained personnel only. In the RDM context, these configurations are the device's DMX PERSONALITY.

The DEC3.2 mode or personality may be configured from the Front Panel or by using an RDM control. In all configurations, the fixture inside the Tempest enclosure may also be an RDM enabled device.

Basic Mode

This is the way your DEC3.2 controller will normally ship from the factory. It will be set up for standalone operation, with settings that will be appropriate for most installations.

In most cases, Basic Mode will work fine for you. You only need to change it if you will be using DMX or RDM (and if these terms are not familiar to you, you probably won't) or if you have to deal with extreme climate conditions. You may set temperature and other parameters while using Basic Mode.

Monitor Mode

The enclosure operates independently, and automatically, requiring no user intervention. Users may set parameters such as temperature and humidity thresholds, and monitor sensor information and DEC status at the DEC3.2 using the display, or remotely, using RDM over a DMX512 network. In this mode, the DEC3.2 does not need to "see" any DMX to operate.

Control Mode

This mode has all of the Monitor Mode features plus control of the Lamp Relay using a single DMX slot at the address configured as the DEC3.2 DMX start address.

A DMX slot value (level) > 75% will cause the fixture to be powered and less than 25% will disconnect the power from the fixture. On DMX fail, the Lamp Relay will default to power the fixture, unless it detects a thermal condition that would cause it to isolate power from the fixture/projector.

DMX control of the Lamp Relay has the useful attribute of enabling the user to remotely force a hard reset of the fixture by controlling power to it. This mode is recommended for show-control applications, where it is desirable to have power control of the internal fixture and accidental loss of the DMX data is very unlikely to occur.

To force a hard fixture reset, take the enclosure's DMX channel to zero (or any level below 25%), allow time for the fixture's power supplies to fully discharge, then restore the enclosure's DMX channel to full (or a level above 75%).

Service Mode

This mode is intended for test and service use only, giving the user direct control of the Lamp Relay, fan and heater controls over three DMX slots. Users may NOT override any of the controls in an unsafe direction – for example, if the DEC3.2 has determined the enclosure is over-temperature and has switched off the power to the fixture, the Lamp Relay may not be controlled by DMX. In this sense, DMX

'piles on' to DEC3.2 operation, within defined safety limits. However, until such time as the temperature reaches the TOP limit, the heater may be enabled and the fan disabled, which is why the mode should only be used for Test and Service use by a trained technician.

DEC3.2 Control Parameters

DEC3.2 will run out of the box with its default parameter settings, which equate to the (fixed) settings of its predecessor DEC's 1 and 2.

Temperature:

Top Set *Range 35-45°C, Default = 40°C*
 Most manufacturers recommend a max temperature for their equipment of 40°C, though this does vary. When DEC3.2 senses a temperature higher than Top Set, it indicates an overtemp condition as a warning. NOTE: in moving light enclosures the thermal sensor is necessarily placed in the exhaust air path, which will be higher (sometimes a lot higher) than the actual fixture ambient. This needs to be kept in mind when adjusting temperature settings.

Cutoff Temp *Range 0-15°C, Default = 15°C*
 This is a setting *above* the Top Set temperature that determines the temperature at which the lamp relay is opened cutting off power from the fixture/projector. User may reduce it as desired, but should establish before doing so the actual operating temperatures experienced in hot weather before doing so, to avoid nuisance tripping.

Bottom Set *Range 0-10°C, Default = 10°C*
 The temperature maintained by the heater in cold conditions. Most equipment manufacturers recommend a minimum operating temperature of 0°C, and users may set it lower than the default if desired.

Humidity *Range 50-90%, Default 80%*
 The threshold at which incoming air is more aggressively heated to remove moisture.

DMX Address *Range 001-510, Default 001*
 Sets the DMX address for the lamp relay control. In the DMX/RDM service mode, the subsequent two DMX slots control fan and heater respectively.

Fan Overrun *Range 1-15 minutes, Default 5 minutes*
 This is the time that the enclosure fan(s) will run after the fixture/projector lamp is turned off. As a general rule, the more powerful the lamp, the longer the overrun should be, to prevent overheating while the lamp cools down.

Temp C/F Default Celsius

DEC3.2 displays temperatures in Celsius or Fahrenheit.

Lamp Hours *Default 0000*

DEC3.2 counts the hours your projector/fixture lamp is on, and can report it both on the user interface display and over RDM. Remember to reset to 0 when changing lamps. This is provided to allow lamp hours monitoring on devices such as Video Projectors that have no native RDM or DMX support.

4 Setup and Connections

DMX Connections

DMX refers to USITT DMX512, a commonly used control protocol in the entertainment industry, running over RS485. Consult USITT DMX installation guidelines when laying out a system, or employ a qualified DMX system integrator.

Note that DMX is optional – in many applications it is not required, and need not be connected. A DMX network will be required if:

- a) The fixture inside the enclosure requires a DMX control signal
- b) You wish to monitor the enclosure using RDM
- c) You wish to control the fixture power over DMX

DMX Terminations

Pinout: (1) Ground, (2) Data -, (3) Data +.

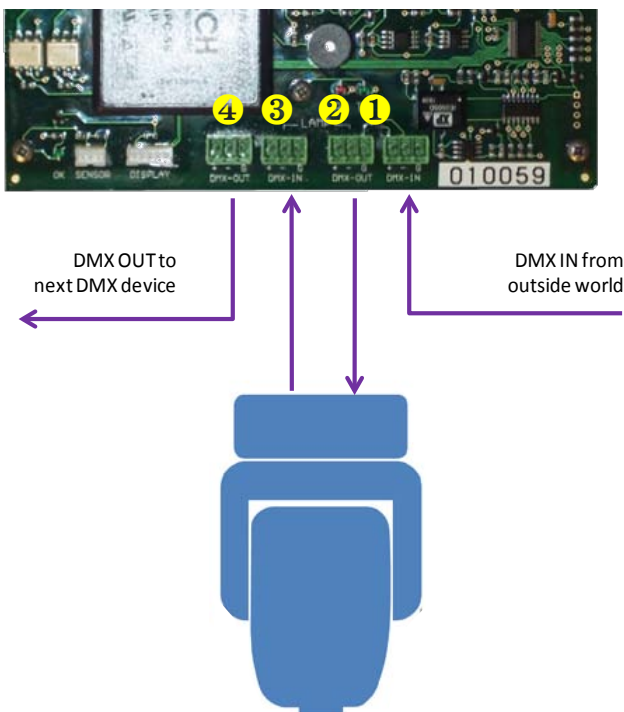

The picture shows the 4 DMX connections on the controller. The incoming DMX feed should always be wired to DMX-IN (1). If the enclosed fixture shares the DMX signal, the fixtures DMX IN should be wired from connection (2) and its DMX OUT wired to connection (3). Connection (4) will then be the DMX OUT for the enclosure. *If the enclosed fixture does not use the DMX connection, then DMX connection (2) on the controller becomes the DMX OUT for the enclosure.*

DMX Line Terminations

DMX cable runs must be terminated at the far end of the cable run with a termination resistor as detailed in the DMX512 standard.

The individual fixtures installed inside the Tempest enclosures must NOT be terminated.

It is recommended that any line termination is done using the 3-pin terminal connector fitted to the DEC3.2 control circuit board.

RDM Connections

RDM refers to ANSI E1.20, a control protocol in the entertainment industry gaining popularity and essentially an “extension” of DMX512. The use of RDM is optional, and uses the same RS485 cable connection as DMX512, so no additional wiring is required.

It is the responsibility of the user to ensure that any DMX splitters or other routing devices used are rated for RDM as well as DMX use.

Power Connections

IMPORTANT Tempest enclosures are supplied for either 120VAC 50/60Hz, or 208-240VAC, 50/60Hz operation. Tempest Lighting is not liable for damage or failure to operate correctly due to connection to an inappropriate electrical supply.

ALL ELECTRICAL CONNECTIONS MUST BE UNDERTAKEN BY A QUALIFIED ELECTRICIAN, IN COMPLIANCE WITH LOCAL NORMS AND STANDARDS.

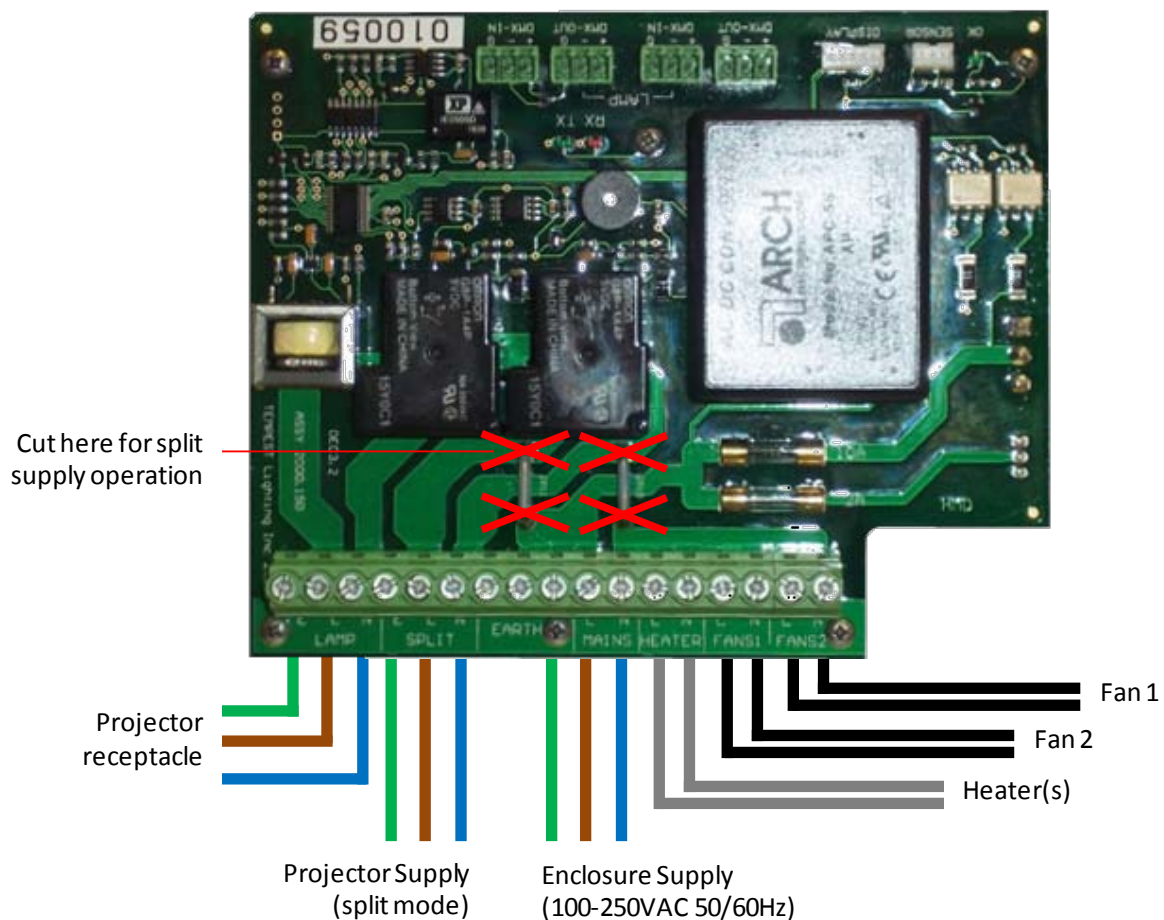

Note: wire colors may differ depending on applicable electrical standards. European wire colors are shown here.

Split or Common Supply Wiring

IMPORTANT: Tempest enclosures with any generation of DEC control MUST be powered 24/7, in order to protect equipment from condensation and temperature extremes.

The AC power feed must be adequate and appropriately fused/protected for the greater of the projector/light fixture load (see manufacturer’s instructions) and the Tempest enclosure (see enclosure manual). *Since the enclosure heater(s) never operate when the projector/fixture lamp is on, it is NOT necessary to rate the power service for the SUM of the enclosure and the projector/light fixture.*

Common Feed operation (factory default)

Tempest Enclosures are normally supplied wired for common electrical supply for the enclosure (DEC3.2) and the projector/light fixture to be enclosed.

Connect incoming power to the terminals labeled MAINS:

(E) Earth/Ground (L) Live (N) Neutral

Split Feed Operation

Split Feed allows you to run the projector/light fixture independently of the enclosure. **The enclosure must be powered 24/7.**

DEC3.2 normally ships from the factory with circuit card power links in place for a common electrical supply to feed the enclosure and the projector/fixture inside it.

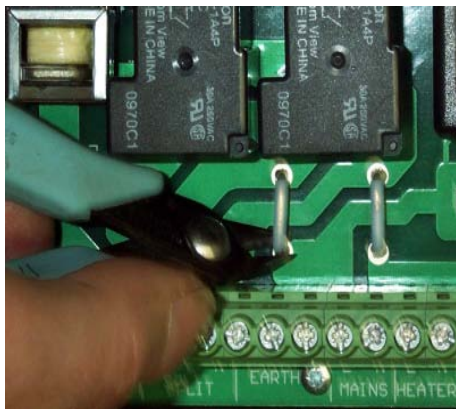

To feed the enclosure and projector separately, you will need to remove the bridging links on the controller circuit board as shown in the illustration, before connecting to mains power.

Use a pair of small side cutters to cut the bridging links from the circuit board, taking care to not damage any tracks on the card.

When splitting the feeders, we strongly recommend feeding both supplies from the same phase and at the same supply voltage.

Feeds must be adequately dimensioned and fused for the loads used.

Connect incoming enclosure power to the terminals labeled MAINS. This supply MUST be maintained 24/7.

(E) Earth/Ground (L) Live (N) Neutral

Connect incoming projector/light fixture power to the terminals labeled SPLIT:

(E) Earth/Ground (L) Live (N) Neutral

Important – RDM and RDM Integration

DEC3.2's RDM implementation allows system integrators to set up remote control and status monitoring of all attributes and sensors, including:

- Relative Humidity
- Air Temperature
- PCB Temperature
- Lamp Current
- Elapsed Lamp Hours
- Lamp Relay Status
- Fan Relay Status
- Heater Relay Status
- DMX Status
- DMX Start Address
- DMX Personality (RDM Mode)
- Device Type
- Device Label
- Software Version



RDM is an effective and powerful tool for commissioning and monitoring an installation, particularly in large systems. For further guidance, we recommend you consult a qualified RDM system integrator. If you don't have one in your neighborhood, go to www.tempestlighting.com, and click on the RDM and RDM Integration bug on the FAQ page for some useful contacts. Tempest Lighting warrants DEC3.2 to be compliant with the RDM standard, but is not an RDM systems integrator, and can offer only basic guidance on RDM utilization.

Control Interface

The control interface features a 2-line display, LED indicators, and 4 sealed control buttons.

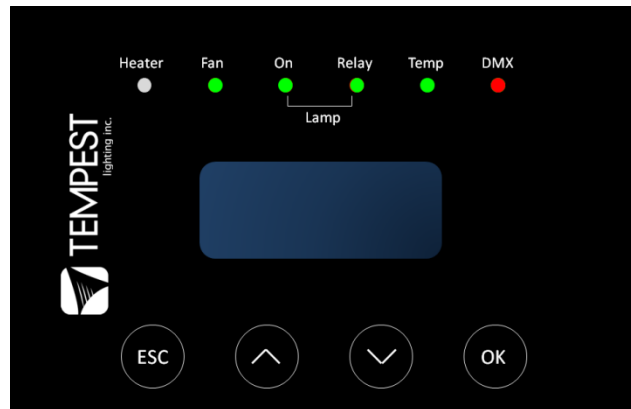

LED Indicators

Heater

SHORT PULSES (Green) - Indicates lamp is off, and the heater is pulsing to prevent condensation inside the enclosure and projector/light fixture. This is normal operation when the lamp is off and the temperature range is above the bottom set limit. Timing intervals may vary - this is normal.

ON (Green) - Indicates heater is on, due to temperature being below bottom temperature setting when lamp is off.

OFF - indicates lamp is on and maintaining temperature above bottom limit.

Fan

SHORT PULSE (Green) - The fan is moving a little air through the enclosure, as part of the condensation prevention strategy. The fan comes on for a few seconds approximately every 30 seconds.

ON (Green) - Fan is running, due to lamp being on or internal temperature exceeding top limit.

Lamp On

ON (Green) Indicates current sensed on the lamp circuit greater than 0.5 amp (this allows some current to be drawn for such things as fans and control electronics without the Lamp On indicator lighting. When the Lamp On indicator is on, the lamp counter is counting lamp life.

Lamp Relay

ON (Green) - Indicates lamp relay closed and power is available to the internal fixture.

OFF Indicates lamp relay open and power is removed from the internal fixture.

Temp

ON (Green) - The temperature is between Bottom and Top temperature settings.

ON (Red) - The temperature is either:

- a) Below Bottom Setting
- b) Above Top setting but below the Cutoff level.

FLASHING (Red) - Temperature is above Cutoff level or below Bottom level.

DMX (Not used in BASIC Mode)

OFF – No DMX received (Basic Mode)

ON (RED) – DMX Fail

ON (GREEN) – Good DMX or RDM data packet received. Note that in Monitor Mode the DMX indicator will only be green when RDM packets are being received. In this case a RED LED is not indicating DMX failure, just that no data is being received from the RDM monitor.

Control Interface Operation

The Control Interface is normally LOCKED.

To UNLOCK, hold ESC and OK together for 5 seconds.

You are now in the CONTROL MENU

Use the arrow keys to scroll up and down the menu.

Press OK, to enter a menu item, then the arrow keys to set the item parameter, or to scroll to the next menu level.

Use ESC to back up a level, and OK to confirm settings.

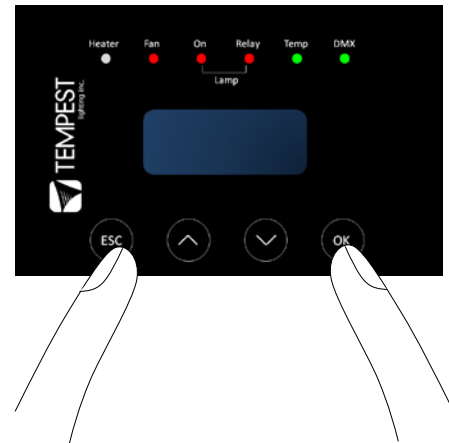

To LOCK, hold ESC for 5 seconds. Menu will time out after ten minutes.

CONTROL MENU

SET DMX ADDRESS (in Monitor, DMX or Service modes)

Select a DMX starting address in the range 001 to 510

1 – Lamp Relay

In Service Mode an addition two slots are available

2 – Fan Relay

3 – Heater Relay

Note that the DMX control is designed using a SAFETY pile-on Logic. So the DMX input can only override automatic settings in a safe manner. For example, if the enclosure has switched off the lamp relay due to an over-temperature condition, the DMX input cannot switch it on, if the fans are running because of Overtemp, the DMX input cannot turn them off, and so on.

SET DMX MODE

From the Front Panel, this menu item allows the user to check (and if necessary change) the RDM mode.

BASIC Standalone operation, no DMX/RDM (factory default)

MONITOR Standalone, plus support for RDM remote configuration and monitoring

CONTROL Monitor, plus use of a single DMX address to control Lamp relay

SERVICE Monitor, plus use of three DMX slots to control Lamp, heater and fan

Important: Please ensure that the DEC3.2 is NOT left in Service Mode.

STATUS DISPLAY

View current status information, using the arrow keys to scroll through:

- a) Humidity – relative humidity in %
- b) Firmware version
- c) Lamp Hours elapsed
- d) Current being drawn by projector/light fixture, in amps
- e) PCB temperature
- f) Air temperature, in degrees C or F (note that sensor is placed in the exhaust airflow in Tornado enclosures and may be higher than the temperature being ‘seen’ by the fixture body or electronics)

RESET LAMP HOURS

The lamp hour counter needs to be reset each time you change the lamp in the fixture/projector. Make this a part of your maintenance instructions.

HUMIDITY SET

The humidity level above which the heater kicks in to remove humidity from incoming air (default 80%, permissible range 50-90%).

SET FAN OVERRUN

The fan will continue to run for a time after the internal fixture has gone to standby. This facility allows the heat built up in the fixture to dissipate before the DEC3.2 resumes normal maintenance of the enclosure.

(default 5 minutes, permissible range 0-15 minutes)

SET TEMP RANGES

Set three temperature trigger points for Bottom, Top and Cutoff temperatures.

TEMP BOTTOM

The desired lower temperature limit for normal operation

(default 10°C, permissible range 0-10°C).

TEMP TOP

The desired upper temperature limit for normal operation

(default 40°C, permissible range 35-45°C).

When the DEC3.2 sees air above this temperature, but below the additional Cutoff temperature (see below), it indicates a temperature error. This is not dangerous.

TEMP CUTOFF

The desired upper temperature ABOVE the TOP TEMP setting, at which the lamp relay is forced to open, isolating the fixture/projector power.

(default 15°C, permissible range 0-15°C).

To avoid nuisance tripping, set this variable to the maximum, and monitor actual temperatures in your normal operating conditions. If your actual temperatures are running lower, then you may reduce the cutoff temperature margin. In hot climates, it may be advisable to set both TOP TEMP and CUTOFF TEMP as high as possible.

SET TEMP C OR F

Choose to display temperature values in Celsius or Fahrenheit (default Celsius)

RDM Monitoring and Configuration

All the features accessible over the DEC3.2 control panel are also available over RDM. Just how this information is displayed will depend on the RDM interface used. The following screen shots were taken running the GetSet program in Windows 7, and connecting to a DEC3.2 controller using a RDM TRI MK1 interface, both from JESE Ltd (jese.co.uk).

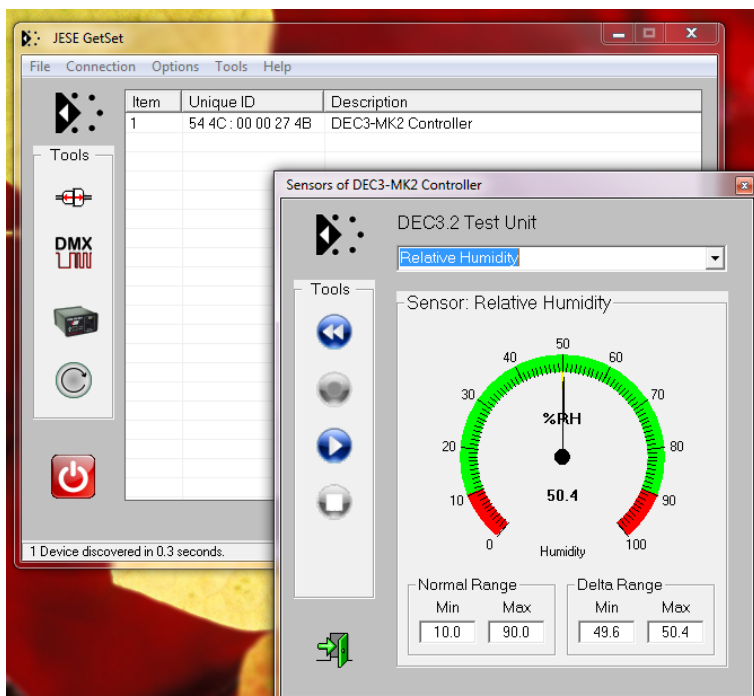
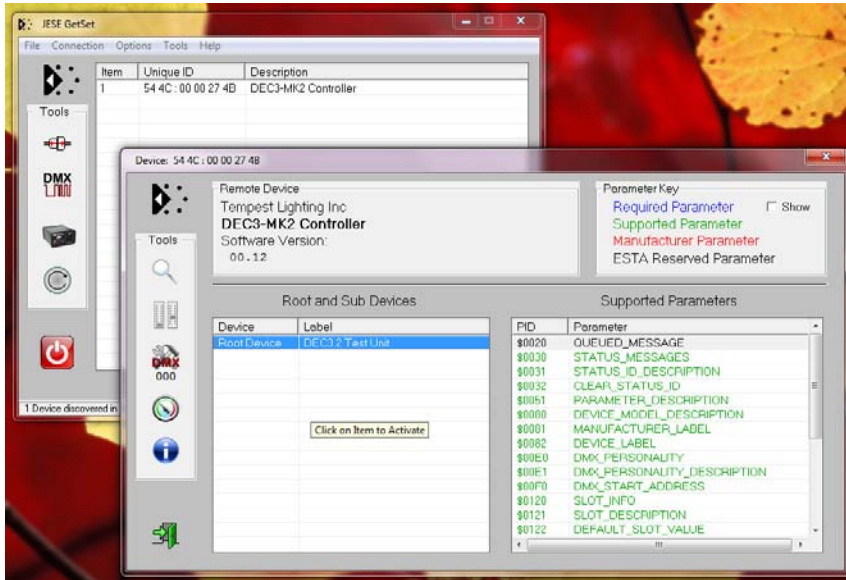

This view shows a single DEC3.2 test unit that has been correctly discovered and labeled by the GetSet software suite, and a log of RDM messages.

This RDM interface provides a graphic view of the various sensor functions supported by DEC3.2 (humidity, air temperature, pcb temperature).

There is a great deal of variability in the way RDM interfaces handle generic and manufacturer-specific

5 Mounting the Projector in the Hurricane Enclosure

 For safety, this must be done by two or more people.

IMPORTANT: The Hurricane enclosure MUST be securely mounted BEFORE you attempt to install the projector.

1. Your Hurricane enclosure is normally supplied with a low-profile yoke already installed, for use with the scanner type specified on your order. These will vary slightly, depending on fixture type.
2. Note carefully how the yoke supplied with your scanner fixture is attached to the fixture.
3. Remove the original yoke supplied with your projector and keep the securing hardware.
4. Carefully place the projector in the yoke mounted in the Hurricane enclosure, and attach it using the hardware removed from the original yoke.
5. MAKE SURE THAT THE MIRROR IS FACING UP (away from the enclosure base), and is positioned approximately center to the projection window. You can move the yoke along its mounting strut to adjust this if you need to.
6. Check that all mounting bolts are tight and secure.
7. Plug the fixture into the receptacle in the DEC cover, and connect the DMX control in compliance with the fixture manufacturer's installation manual.

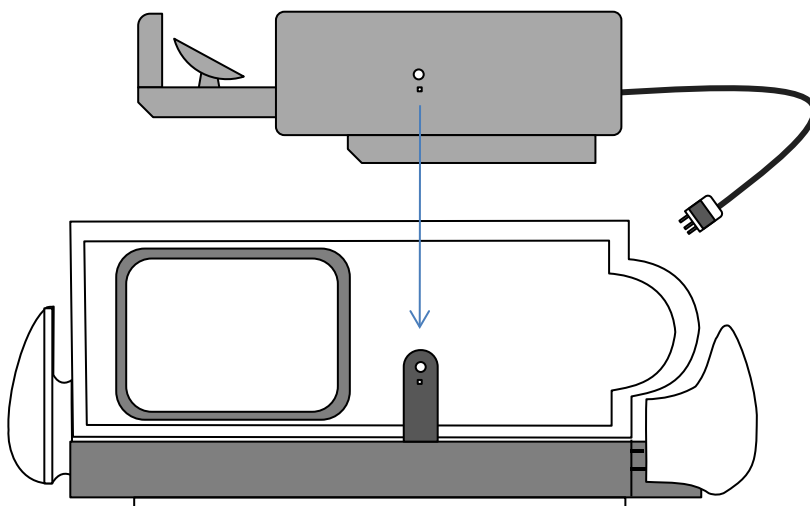

6 Activation and Checkout

Now the installation is complete, the time has come to activate the enclosure and make sure it is working properly.

 Be aware that once the enclosure has had power applied to it, the heaters will get hot and the fans will start to turn. Make sure that your hands and any cables or other objects are clear of both of these areas before applying power to the enclosure.

1. Clear enclosure and projectors of all debris.
2. Set up the projector in accordance with the manufacturer's instructions.
3. Focus the projector, then close the enclosure cover.
4. The system is now ready for use.

Note

The enclosure can be secured with padlock at this point. Only qualified personnel should be accessing the enclosure.

7 Operation

See section 4 for detailed operating instructions.

- ① **Regardless of whether the projector is in use, power must be maintained to the enclosure at ALL TIMES. The Digital Enclosure Control system will work 24/7 to ensure that optimum temperature and humidity are maintained, preventing condensation, overheating and freezing. This is critical to attaining optimum projector lifetime.**
- ① The cooling fans will only turn when power is applied to the enclosure. Fans will stop turning when power is cut to the enclosure, but the heater may remain hot to the touch for up to one hour - be careful when opening the enclosure immediately following a power down.
- ① Unless the enclosure or projector is undergoing routine maintenance, the enclosure should be closed and securely latched at all times.
- ① Only authorized personnel should open the enclosure (see maintenance warnings in the next chapter).
- ① If the safe operating temperature is exceeded, the over-temperature shutdown feature may engage and temporarily cut off power to the projector. Once the temperature reaches acceptable levels, power will be automatically restored. This is extremely unlikely to occur during hours of darkness when the projector is in use. To avoid nuisance cutoffs, set the Top Temp and Cutoff Temp settings to their maximum (see chapter 4)
- ① **Do not** routinely operate projector in full sun in hot weather. The enclosure has not been designed to protect the projector in this extreme condition.





8 Routine Maintenance

It is very important to perform routine maintenance on both the enclosure and the projector inside it. Failure to do so may reduce lifetime for both the enclosure and the projector.

Note

Maintenance schedules depend on location and environment. The intervals given here are general minimum guidelines. It is up to the user to judge whether maintenance should be carried out more frequently. We recommend doing these tasks no less often than mentioned here.

Safety

-  As the enclosure is a powered unit with moving parts, it is necessary to keep safety in mind while performing routine maintenance. Although maintenance can be performed while the enclosure is powered, it is safer to carry it out with the power disconnected with proper lockout and tag out procedures followed.
-  Be aware that once the enclosure has had power applied to it, the fans will start to turn. Make sure that your hands are clear of the fans before applying power to the enclosure.
-  Only authorized personnel should perform maintenance on the enclosure or luminaire
-  Do not service the unit in the rain or other adverse weather conditions (snow, sleet, high winds, etc.).

Inspection Checklist: - Every Three (3) Months

- Glass should be clean and free of cracks
- Enclosure should be free of debris both inside and out
- Bolts should be tight
- All safety cable should be in good condition
- Door seals should be in good condition. Check seals inside and out for gaps.
- Fans should be functioning and not making excessive noise
- Fan filters should be clean
- Drainage holes free of obstruction

Air Filters - Every Three (3) Months

The air filter from the intake vent on rear of enclosure (left side) should be removed and cleaned on a regular basis. To remove filters, open the enclosure, reach into the inlet duct, and pull out the filter. The filters can be cleaned by running water from a hose and do not require any special cleaning solution.

To reinstall, push filter fully back into the inlet duct until it presses on the inside of the inlet cowl. The filter will be held in place by velcro tabs.

Warning: Make sure that the filter is never left in contact with the heater, when the enclosure is in use.

Replacement filters may be obtained from your Tempest Lighting Dealer.

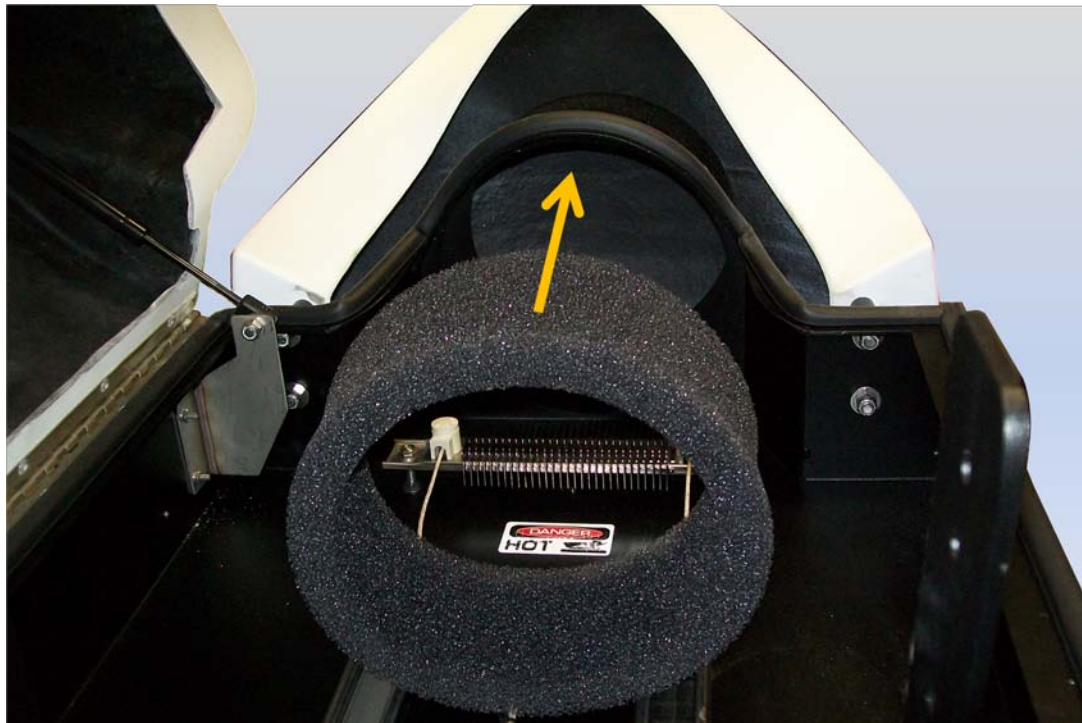

Case - As Needed

The outside of the case should be cleaned as needed. The case should be cleaned with a wet cloth and mild detergent (if necessary). Do not use a direct spray from a hose to clean the case. Do not use hydrocarbon-based cleaners.

Window - As Needed

Clean using a proprietary glass cleaning solution or a mild detergent, and wipe dry. Use only soft, lint-free cloths for glass cleaning. Never use an abrasive cleaner.

Projector

Review the manufacturer's instructions for proper maintenance of your luminaire/projector. Remember, the enclosure simply protects the equipment inside it and is not a substitute for regular maintenance.

9 Troubleshooting

This is a guide to the general symptoms, problems, and solutions that may occur during the usage of your enclosure. However, it is important to remember that problems may occur within the luminaire itself and these must also be considered.

Projector does not have power.

Check power supply wiring and voltage.

One or more fans are not spinning

Fans may be obstructed. Shut off power to enclosure and check for obstructions. Turn power back on to see if fans will start spinning. If fans do not turn and display on temperature controller is lit, contact technical support. If fans do not turn display is not lit, then enclosure is not receiving power. Turn off all power and check wiring. If the wiring is correct, contact technical support.

Fan cords may have become disconnected. Check connections between fan and cord. Make sure that the ribbed side of the cable is on the positive side of the connection (the fans are DC powered).

Projector does not have power.

Check projector power switch. (Note: the following actions should be performed by a licensed electrician) If switch is on, check wiring (including metering supply voltages, enclosure must receive 200-240VAC to operate properly).

In case of over-temperature, the enclosure shuts down power to the projector, for its protection. Projector power will be restored when temperature drops to an acceptable level. It is possible that the air intake or exhaust has become clogged, leading to higher temperatures inside the enclosure. Make sure that these areas are clear, the filters are clean, and the fans are working properly.

Projector turns on and off repeatedly over short span of time.

Check that vent areas and airways are clear. If so, ambient temperature may be too high (see over-temperature note above) or projector may have internal problem.

Excessive water in enclosure.

Glass seal leak. Repair with silicone sealant.

Door gaskets leak caused by separation. Silicon piece back into place or replace section.

10 Sample Specification

Unit shall be a Tempest Hurricane lighting enclosure catalog number 1000-__-__. The housing shall be constructed from aluminum, fiberglass and stainless steel. Further, the unit shall possess filtered forced air ventilation in combination with heater and controlled by a microprocessor with a temperature display. Unit shall be designed to U.L. standard 508 for wet locations and be a NEMA type 3R. The unit shall have above ground connection ports, compression latches with padlock rings, and may be secured to its mounting via stainless steel Unistrut members. Unit shall provide a power cutoff to fixture in case of high temperature inside enclosure. Units shall control cool-down rate of projector by use of heater. Unit shall have a projection window with optically clear safety glass. The enclosure shall be identified as The Hurricane Enclosure manufactured by Tempest Lighting, Inc., of North Hollywood, California, USA.

11 Limited Warranty

INSPECTION/WARRANTY/RETURNS.

A. Customer, at its sole expense, shall inspect all Goods promptly upon receipt and accept all Goods that conform to the specifications or catalog. All claims for any alleged defect in or failure of the Goods or Seller's performance to conform to the Contract, capable of discovery upon reasonable inspection, must be set forth in a written rejection notice detailing the alleged non-conformity, and be received by Seller within thirty (30) calendar days of Customer's receipt of the Goods. Failure by Customer to notify Seller of the alleged non-conformity within thirty (30) days will be conclusive proof that the Goods have been received by Customer without defects or damage, and in the quantities specified on the bill of lading and shall constitute an irrevocable acceptance of the Goods and a waiver of any such claim in connection with the Goods.

B. Seller warrants to Customer only that the Goods will be free from defects in material and workmanship at the time of delivery and, subject to the exceptions and conditions set forth below, for the following period (the "Warranty Period"): twelve (12) months from the date of shipment by Seller. Seller may provide additional years of warranty coverage beyond 12 month, at the rate of 2.5% of the net sale price per year, up to a total of four additional years' coverage beyond the standard 12 month warranty period. Seller will remedy a defect as set forth in paragraph 7 D, below, (the "Warranty"). The Warranty is subject to each of the following exceptions and conditions:

1. Customer must promptly (and in all events within the Warranty Period) notify Seller of any alleged defect in a written notice (the "Notice") which shall set forth the quantity, catalog number, finish, original purchase order number, Seller's invoice number on which Goods were originally billed and a statement of the alleged defect, along with digital photographs showing such defects where feasible.

2. The Warranty shall not apply: (i) to any claimed defect that was capable of discovery upon reasonable inspection and deemed to be waived under paragraph A, above; (ii) to any Goods that have been subject to misuse, abnormal service or handling, or altered or modified in design or construction; (iii) to any Goods repaired or serviced by any person other than Seller's authorized service personnel or to Goods installed other than according to installation instructions, or (iv) with respect to normal wear and tear.

3. Seller makes no Warranty with respect to parts or components that are not the product of Seller, and specifically makes no warranty whatsoever for equipment housed inside enclosure products manufactured by Seller.

4. The Warranty is Seller's exclusive warranty with respect to the Goods. Seller makes no warranties, guarantees or representations, express or implied, to Customer except as set forth in this section. ALL OTHER WARRANTIES, EXPRESS OR IMPLIED, INCLUDING, WITHOUT LIMITATION ANY IMPLIED WARRANTY OF MERCHANTABILITY OR OF FITNESS FOR USE OR FOR A PARTICULAR PURPOSE, ARE HEREBY EXCLUDED AND DISCLAIMED.

C. Seller will accept the return of Goods properly rejected under paragraph A, above, or as to which Notice of an alleged breach of Warranty has been timely given and such Goods may be returned to Seller, freight prepaid, but only upon Customer's receipt of Seller's written return material authorization ("RMA") and shipping instructions. The RMA shall be void if the Goods are not received within 45 days after issuance of the RMA. No deduction or credit in respect of any rejected or returned Goods shall be taken until Customer has received Seller's further written deduction or credit/authorization following Seller's inspection to confirm nonconformity or defect. Seller will charge to Customer any and all costs incurred by Seller in connection with the handling, shipping, inspection and disposition of any returned Goods that are determined by Seller not to have been nonconforming upon Delivery or as to which the warranty hereunder is not applicable.

D. UPON ANY PROPER RETURN PURSUANT TO PARAGRAPH C, ABOVE, WHETHER IN CONNECTION WITH A REJECTION OF GOODS OR AN ALLEGED BREACH OF WARRANTY AND BASED UPON THE CONDITIONS SET FORTH IN THIS PARAGRAPH 7, SELLER AGREES THAT IT WILL, AS THE SOLE AND EXCLUSIVE REMEDY UNDER THE CONTRACT OR OTHERWISE, FOR ANY NONCONFORMITY OR BREACH OF WARRANTY, AND AT SELLER'S SOLE ELECTION: (i) REPAIR SUCH GOODS; OR (ii) REPLACE SUCH GOODS.

12 Tempest Product Support

Step 1: First contact your local Dealer for support. Your dealer is best placed to respond quickly to your needs.

Step 2: If your dealer is unable to answer your questions please contact:

Tempest Lighting, Inc.

13110 Saticoy Street, CA 91605 USA

Tel +1 818 787 8984

Fax +1 818 982 5582

info@tempestlighting.com

Visit our web site for current information and specifications:

www.tempestlighting.com

13 Registration

Filling out the registration form on the next page and sending it to the Tempest Lighting factory within 30 days of installation entitles you to the warranty cover specified in this manual. It also enables us to notify you in case of important news or post-sale information regarding the Hurricane Lighting Enclosure.

Hurricane Enclosure Registration Form

Detach and mail/fax to:

Tempest Lighting, Inc., 13110 Saticoy St., N Hollywood, CA 91605

Fax # +1 818 982 5510

If a Tempest Representative has not inspected the installation, please send photos showing installation.

Model Number:

Serial Number:

Latch Key Number:

Dealer/Sold By

Name:

Location:

Date Purchased:

Contractor/Installed By

Name:

Date Installed:

Location Installed:

Company/Organization

Name:

Street Address:

.....

City, State, ZIP, Country:

.....

Phone:

Fax:

Contact Information

Name:

Phone: Extension:

Fax:

E-mail:

DMX Connections

DMX refers to USITT DMX512, a commonly used control protocol in the entertainment industry, running over RS485. Consult USITT DMX installation guidelines when laying out a system, or consult a qualified DMX system integrator.

Note that DMX is optional – in many applications it is not required, and need not be connected. For more information, see DEC3 Operating Modes in the next section.

DMX IN – Connect incoming DMX to the 2-part 3-pin terminal on the DEC3 control circuit board so labeled.

Pinout: (1) Ground, (2) Data –, (3) Data +.

DMX THRU – there are two DMX pass-through terminals – one for a fixture inside the enclosure, the other to run to the next DMX device in the network.

Pinout: (1) Ground, (2) Data –, (3) Data +.

DEC3 Control – Introduction

Tempest Lighting and Projector Enclosures have been in daily use around the world for almost a decade. Tempest enclosures protect expensive and delicate equipment in all climates, maintaining a comfortable operating temperature, and preventing condensation – the real outdoor enemy.

DEC3™ – that’s *Digital Enclosure Control, third Generation* – is the brain of your Tempest enclosure. It will maintain the internal environment in a comfortable temperature and humidity range, and prevent condensation – the real equipment killer. DEC3 monitors internal temperature, humidity and lamp current at all times, and uses this information to control its lamp relay, fan(s) and heater(s). It can report back over the DMX cable, using the RDM protocol (Remote Device Management) if desired.

Unless otherwise specified, this version of the user guide refers to DEC3 units fitted with software version 2.1 or later.

So, what does DEC3 actually DO?

DEC3 is the brains of the operation – here’s a layout:

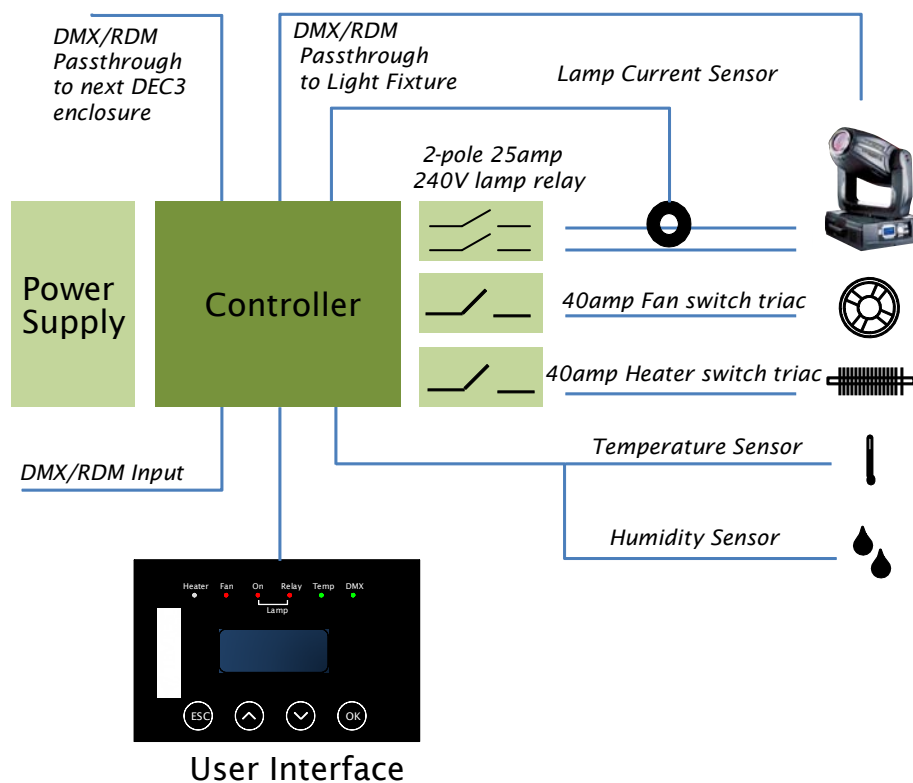

This schematic shows the relationship between DEC3’s functional elements. The power supply is universal 90-260V, but fans and heaters are either 120V or 230VAC, and must be so specified. A high-quality 25amp 2-pole electro-mechanical relay isolates fixture/projector power in the event of an over-temperature condition. Fans and heaters are switched using generously overrated 40amp Triac devices for maximum reliability. Two DMX outputs connect to the internal fixture (if desired) and on to other enclosures or DMX devices.

DEC3’s mission is to maintain temperature and humidity inside the enclosure, within determined bounds, and to prevent condensation – particularly overnight dew formation – inside the equipment housed. Condensation is fatal to electronic equipment, particularly in polluted areas or saline environments, where it brings not only rust and short-circuits, but also a steady buildup of mineral and/or salt deposits. Incidentally, condensation is very hard to control with air-conditioning type systems, which is why we don’t use them.

Broadly speaking, DEC3’s function depends on whether the fixture/projector lamp is on or off:

Lamp ON

When the projector/fixture is running, the heat from the lamp takes care of humidity, and DEC3 runs the enclosure's fan(s) to change its air every few seconds – ensuring minimal temperature rise above outside ambient.

Lamp OFF

When the lamp is off, DEC3 senses temperature and humidity and controls its fan(s) and heater(s) accordingly. When conditions are within normal bounds (between top and bottom temperature settings and below the humidity threshold (see below), DEC3 pulses the heater at a low level to dry the air and eliminate condensation, and runs the fans to change the enclosure air every 30 seconds or so. We call this 'pulse mode', and it is the key to preventing damaging condensation inside your equipment.

If the temperature rises above the top set limit (see below), DEC3 runs the fans to cool it down. In cold conditions, DEC3 will run the heater as required to maintain the bottom set temperature.

Thus, DEC3 maintains a comfortable operating temperature inside the enclosure, and prevents damage from condensation. Users all over the world have found that Tempest enclosures provide an optimal environment for expensive and delicate equipment, in every climate type.

And while doing all of this, DEC3 can tell you what's happening over your RDM network – a real boon in larger installations.

Operating Modes

DEC3 may be run in one of three basic operating configurations. A fourth configuration is provided for test and service use.

Standalone: The enclosure operates independently, and automatically, requiring no user intervention. User may set parameters such as temperature and humidity thresholds, and monitor sensor information and DEC status at the DEC3 user interface. Standalone is the default DEC3 shipping mode unless specified otherwise at time of order. DMX is not required or utilized.

DMX/RDM Mode 1 (RDM Monitor)

All of the Standalone features plus the ability to discover and monitor the DEC3 over a DMX512 connection, using RDM.

In this mode, the DEC3 does not need to “see” any DMX to operate. The mode allows the use of RDM to set the various temperature thresholds, and monitor the conditions inside the enclosure remotely. The fixture inside the Tempest enclosure may also be an RDM enabled device.

DMX/RDM Mode 2 (DMX Enable)

All of the Standalone and RDM Monitor features plus the use of a single DMX address (slot) to control the Lamp Relay.

This means that the user is responsible for maintaining a DMX input with the slot (as selected as the DMX START ADDRESS on the DEC3) high. This slot level must be set greater than 50% at all times when the internal fixture is to be powered. This has the useful attribute of enabling the user to remotely force a hard reset of the fixture by opening and then closing the Lamp Relay. It also means that it is unnecessary to feed the enclosure with two power sources (for the enclosure and the luminaire/projector), since the DMX slot may be used to isolate the projector when not in use, without removing power from the enclosure. This mode is recommended for show-control applications, where it is desirable to have power control of the internal fixture, and accidental loss of the DMX data is very unlikely to occur.

In the absence of DMX, the Lamp Relay defaults to “ON”.

All RDM functions are available for configuration and monitoring of the DEC3.

DMX/RDM Mode 3 (Service/Test)

This mode is intended for test and service use.

It gives the user direct control of the lamp, fan and heater relays over DMX. User may NOT override any of the relays in an unsafe direction – for example, if the DEC3 has determined the enclosure is over-temperature and has switched off the lamp relay, the relay may not be overridden ON by DMX. In this sense, DMX ‘piles on’ to DEC3 operation, within defined safety limits. However, until such time as

the temperature reaches the TOP limit, the heater may be enabled and the fan disabled, which is why the mode should only be used for Test and Service use.

If the DEC3 has been purchased with DMX/RDM enabled, it is possible to select the required mode 1-3 using RDM. In the RDM context, this is known as selecting the device’s DMX PERSONALITY. Setup of the DEC3 from the Front Panel is available in all configurations.



RDM is an effective and powerful tool for commissioning and monitoring an installation, particularly in large systems. For further guidance, we recommend you consult a qualified RDM system integrator. If you don’t have one in your neighborhood, go to www.tempestlighting.com, and click on the RDM and RDM Integration bug on the home page for some useful contacts. Tempest Lighting warrants DEC3 to be compliant with the RDM standard, but is not an RDM systems integrator, and can offer only basic guidance on RDM utilization.

DEC3 Control Parameters

DEC3 will run out of the box with its default parameter settings, which equate to the (fixed) settings of its predecessor DEC’s 1 and 2.

Temperature:

- Top Set** *Range 35-45°C, Default = 40°C*

Most manufacturers recommend a max temperature for their equipment of 40°C, though this does vary. When DEC3 senses a temperature higher than Top Set, it indicates an overtemp condition as a warning. NOTE: in moving light enclosures the thermal sensor is necessarily placed in the exhaust air path, which will be higher (sometimes a lot higher) than the actual fixture ambient. This needs to be kept in mind when adjusting temperature settings.
- Cutoff Temp** *Range 0-15°C, Default = 15°C*

This is a setting *above* the Top Set temperature that determines the temperature at which the lamp relay is opened, cutting off power from the fixture/projector. The user may reduce it as desired, but should establish before doing so the actual operating temperatures experienced in hot weather before doing so, to avoid nuisance tripping.
- Bottom Set** *Range 0-10°C, Default = 10°C*

The temperature maintained by the heater in cold conditions. Most equipment manufacturers recommend a minimum operating temperature of 0°C, and users may set it lower than the default if desired.

The threshold at which incoming air is more aggressively heated to remove moisture. This parameter will not normally require adjustment.

DMX Set *Range 001-510, Default 001*

Sets the DMX address for the lamp relay control. In the DMX/RDM service mode, the subsequent two DMX slots control fan and heater respectively.

Lamp Hours *Default 0000*

DEC3 counts the hours your projector/fixture lamp is on, and can report it both on the user interface display and over RDM. **Remember to reset to 0 when changing lamps.** This is provided to allow lamp hours monitoring on devices such as Video Projectors and certain moving lights that have no native RDM or DMX support.

Setup and Connections

Operating Mode Setup

Your DEC3 will normally be factory set to the operating mode you specified in your order:

Operating Mode DIP Switch Settings

Mode	DIPswitch Settings	Mode Summary
Standalone	1-6 OFF	Standalone - no DMX/RDM
DMX/RDM	2 ON, 1, 3-6 OFF	DMX/RDM Modes 1-3 - support for remote monitoring

DMX Connections

DMX refers to USITT DMX512, a commonly used control protocol in the entertainment industry, running over RS485. Consult USITT DMX installation guidelines when laying out a system, or employ a qualified DMX system integrator.

Note that DMX is optional - in many applications it is not required, and need not be connected.

DMX IN - Connect incoming DMX to the 2-part 3-pin terminal on the DEC3 control circuit board so labeled.

Pinout: (1) Ground, (2) Data -, (3) Data +.

DMX THRU - there are two DMX pass-through terminals - one for a fixture inside the enclosure, the other to run to the next DMX device in the network. Pinout: same as DMX IN.

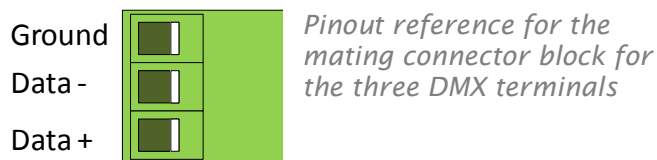
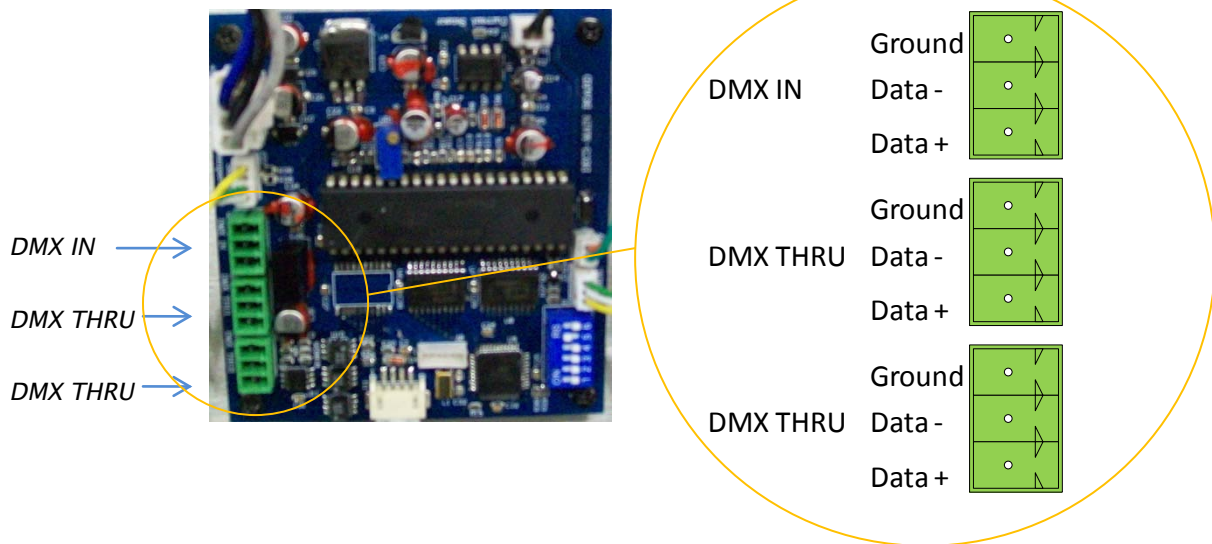

DMX Line Termination

DMX cable runs must be terminated at the far end of the cable run with a termination resistor as detailed in the DMX standard. This is particularly important for satisfactory operation of DMX/RDM

installations. The individual fixtures installed inside the Tempest enclosures must NOT be terminated. It is recommended that any line termination is done using the 3-pin terminal connector fitted to the DEC3 control circuit board.

1. Make sure that any DMX termination provided by the fixture inside your enclosure(s) is disabled.
2. The LAST enclosure in the installed DMX daisy chain should have a DMX Termination fitted to one of the pass through DMX connectors. Per the ANSI E1.11 standard, the Terminator shall be 120 ohm +5%/-10% impedance placed between Data+ and Data-. We recommend minimum power rating of 0.6W for the resistor.
We recommend that the installer fit a label externally to say "DMX Termination fitted internally".

Test:

3. Switch mains power OFF to all enclosures.
4. Before connecting the DMX line to your controller, measure the impedance between Pin 2 (Data-) and Pin 3(Data+) at the controller end. Reading should be around 100-130 ohms.

This test shows that you have a terminator in place, and also that you have continuity of Data- and Data+ between installed devices. If the measured resistance is significantly less than 100 ohms, (say 40-80 ohms) it suggests you may have multiple terminations in place. Check that any terminator switches on light fixtures are OFF. If impedance is very low, check for wiring shorts.

RDM Connections

RDM refers to ANSI E1.20, a control protocol in the entertainment industry gaining popularity and essentially an "extension" of DMX512. The use of RDM is optional - but it does require a DMX512 cable connection.

Important – RDM and RDM Integration

RDM (Remote Device Management) is an ANSI standard that adds bidirectional discovery and status monitoring to a standard DMX network connection. No additional wiring is required for RDM operation.

DEC3's RDM implementation allows system integrators to set up remote control and status monitoring of all attributes and sensors, including:

- Temperature
- Humidity
- Lamp Current
- Elapsed Lamp Hours
- Lamp Relay Status
- Fan Relay Status
- Heater Relay Status
- DMX Status
- DMX Start Address
- DMX Personality (RDM Mode)
- Device Type
- Device Label
- Software Version

Tempest Lighting warrants that its RDM products are compliant to the RDM standard, but does not directly support RDM system integration. Tempest Lighting will however provide introductions to qualified RDM system integrators for customers requiring assistance in this area. Links are provided on the Tempest Lighting web site (www.tempestlighting.com).

DEC-3 RDM Supported parameters

DEVICE -INFO
IDENTIFY -DEVICE
DMX -START -ADDRESS
SOFTWARE -VERSION-LABEL
PARAMETER -DESCRIPTION
QUEUED -MESSAGE
STATUS -MESSAGES
STATUS -ID -DESCRIPTION
CLEAR -STATUS -ID
MANUFACTURER -LABEL
DEVICE -LABEL
SENSOR -DEFINITION
SENSOR -VALUE
LAMP - HOURS
DEVICE -MODEL -DESCRIPTION
SLOT -INFO
SLOT -DESCRIPTION
DMX -PERSONALITY
DMX -PERSONALITY -DESCRIPTION
TOP TEMP
BOTTOM TEMP
CUTOFF TEMP

Control Interface

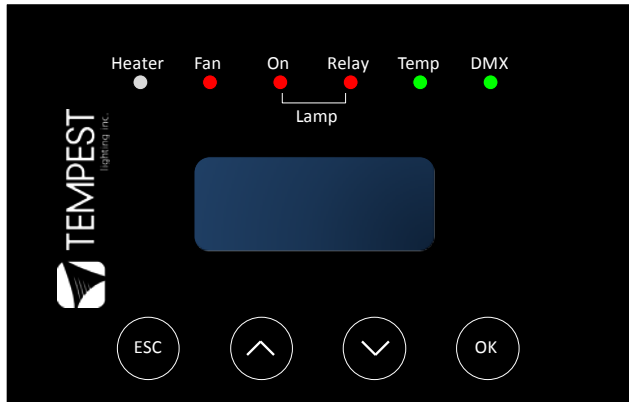

The control interface features a 2-line display, LED indicators, and 4 cap-sense control buttons.

LED Indicators

Heater

SHORT PULSE (RED) - Indicates lamp is off, and the heater is pulsing to prevent condensation inside the enclosure and projector/light fixture. This is normal operation when the lamp is off and the temperature range is above the bottom set limit.

ON (RED) - Indicates heater is on, due to temperature being below bottom temperature setting when lamp is off.

OFF - indicates lamp is on and maintaining temperature above bottom limit.

Fan

SHORT PULSE (RED) - The fan is moving a little air through the enclosure, as part of the condensation prevention strategy. The fan comes on for a few seconds approximately every 30 seconds.

ON (RED) - Indicates fan is running, due to lamp being on or internal temperature exceeding top limit.

Lamp Relay

ON (RED) Indicates lamp relay closed and power is available to the internal fixture/projector.

OFF Indicates lamp relay open and power is removed from the internal fixture.

Lamp On

ON (RED) Indicates current sensed on the lamp circuit greater than 1 amp (this allows some current to be drawn for such things as fans and control electronics without the Lamp On indicator lighting. When the Lamp On indicator is on, the lamp counter is counting lamp life.

Temp

ON (GREEN) - The temperature is between Bottom and Top temperature settings.

FLASHING (RED) - The temperature is above Top setting but has not yet reached the Cutoff level.

ON (RED) - Temperature is above Cutoff level or below Bottom level.

DMX (only used when DMX/RDM setting is in effect)

ON (RED) - DMX error.

ON (GREEN) - Good DMX or RDM data packet received.

Control Interface Operation

The Control Interface is normally LOCKED.
 To UNLOCK, touch ESC and OK together for 5 seconds.
 You are now in the CONTROL MENU
 Use the arrow keys to scroll up and down the menu.
 Use OK, to enter a menu item, then the arrow keys to set the item parameter, or to scroll to the next menu level.
 Use ESC to back up a level, and OK to confirm settings.

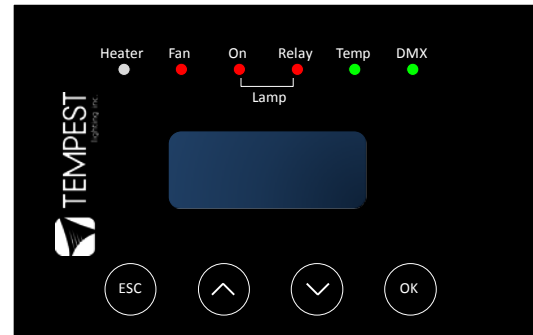

Depending on the Operating Mode selected, and present status, DEC3's display shows you temperature, humidity, DMX address and a selection of error and status messages.

CONTROL MENU

DMX SET (if DMX/RDM mode 2 or 3 is selected)

Select a DMX starting address in the range 001 to 510

1 - Lamp Relay

In RDM Mode 3 an addition two slots are required

2 - Fan Relay

3 - Heater Relay

Note that the DMX control is designed using a SAFETY pile-on Logic. In other words, the DMX input can only override automatic settings in a safe manner. For example, if the enclosure has switched off the lamp relay due to an over-temperature condition, the DMX input cannot switch it on, if the fans are running because of Overtemp, the DMX input cannot turn them off, and so on.

The DMX SET menu can be ignored if the DEC3 is in Standalone or DMX/RDM Mode 1 (RDM Monitor) mode.

SET LAMP HOURS TO 0

The lamp hour counter needs to be reset each time you change the lamp in the fixture/projector. Make this a part of your maintenance instructions.

STATUS DISPLAY

View Temperature (in Celsius) and Relative Humidity (in %) inside the enclosure. Note that in Tornado moving light enclosures the temp/humidity sensor is located in the exhaust airflow, which may be significantly warmer than ambient.

HUMIDITY SET

The humidity level above which the heater kicks in to remove humidity from incoming air (default 80%, permissible range 50-90%). This setting should not normally be changed.

TEMP SET

Set three temperature trigger points for Top, Cutoff and Bottom temperatures.

TOP TEMP

The desired upper temperature limit for normal operation (default 40°C, permissible range 35-45°C).

When the DEC3 sees air above this temperature, but below the additional Cutoff temperature (see below), it indicates a temperature error. This is not dangerous, but may reduce lamp life.

CUTOFF TEMP

The desired upper temperature ABOVE the TOP TEMP setting, at which the lamp relay is forced to open, isolating the fixture/projector power.

(default 15°C, permissible range 0-15°C).

To avoid nuisance tripping, set this variable to the maximum, and monitor actual temperatures in your normal operating conditions. If your actual temperatures are running lower, then you may reduce the cutoff temperature margin. In hot climates, it may be advisable to set both TOP TEMP and CUTOFF TEMP as high as possible.

BOTTOM TEMP

The desired lower temperature limit for normal operation

(default 10°C, permissible range 0-10°C).

Note that a higher BOTTOM TEMP may provide additional protection against condensation in some conditions, but will consume more energy. Therefore a lower setting is desirable, provided the user is certain that no condensation is occurring.

RDM MODE SET

The RDM Mode is normally set using RDM commands from a remote RDM control device to set the DMX PERSONALITY of the DEC3.

From the DEC3 user interface, this menu item allows the user to check (and if necessary alter) the RDM mode. Please ensure that the DEC3 is NOT unintentionally left in Mode3 (Service/Test).